

Ref. no. 31-893C-0201-01/2039

Operating Instructions

BLUE11 EASYSET

EN |

Original language instruction

Contents/ Information	2	Manual adjustment of magnet finger position.....	11
Warnings	3	Main parts	13
Technical Specifications.....	4	Balloon Control/ Threading	14
Installation/ Mains Connection.....	5	Rotating the spoolbody.....	15
Handling	6	Maintenance.....	16
Operating diagram/ Connections feeder pneumatics	7	Fault finding.....	17
Connections interface	8	Accessories - Bobbin Switch Sensor.....	18
System Orientation.....	9	Accessories - Multi yarn break sensor system	19-21
Settings Spool Body Circumference	10		

This section contains important safety information. Read the manual carefully before installing, using or maintaining the weft feeder.



WARNING

Indicates a possible dangerous situation which could result in serious injury or damage to the unit.



CAUTION

Indicates a possible dangerous situation which could result in minor/moderate injury or damage to the unit.

NOTE

Used in order to draw attention to important information, which facilitates operation or handling.



It is recommended to use suitable respiratory, eye and hearing protection when operating this equipment and depending on operating activity.

IRO AB reserve the right to change the contents of the user's guide and technical specifications without prior notification.

**WARNING**

- The loom must be switched off at the mains before any work is carried out on the feeder, interface or cables. The weft feeder ON/OFF-switch DOES NOT cut off the main power supply.
- Always turn off the main switch before connecting or disconnecting the feeder, the interface control board, cables or any of the circuit boards or electrical components.
- The feeder and the interface box contain electrical components that retain an electric current up to one minute after switching off loom main power. DO NOT open or disconnect feeder or interface, including cables, within this time.
- The feeder, interface cabinet and cables must be fully assembled before the power is switched on.
- All work on electrical components must be carried out by a qualified electrician.
- This product is NOT intended for use in potentially explosive atmospheres or in zones classified according to the European directive 2014/34/EU.
- Routine checks for damaged or worn parts must be made before operating this equipment. Any part that is worn or damaged should be properly repaired or replaced by authorized personnel. To avoid risk of injury DO NOT operate this equipment if any component does not appear to be functioning correctly.
- Take necessary precautions to avoid injuries when interacting with the product, depending on activity.



- Improper handling at repair, fault finding or similar may damage the feeder/interface mechanical/electrical components including cables and connectors. DO NOT perform measurements on feeder electrical components and parts.
Please contact your local IRO service station for further information.

**CAUTION**

- Caution must be taken in the close vicinity of the feeder as it contains moving parts that can cause injuries and, in normal operation, starts without prior warning.
- To comply with C.E. Regulations only replacement parts approved by IRO AB may be used.
- The feeder is an industrial product and therefore not approved to use in household environments / residential areas.

NOTE

To ensure the selection of the most suitable feeder and associated accessories, it is recommended making weaving tests with the intended yarns.

Please dispose of obsolete or unwanted equipment responsibly, taking into consideration any local regulations regarding the disposal and / or recycling of materials that are applicable

Blue11 EasySet, with possibility to set insertion length via loom terminal, can handle most yarns and running conditions. To ensure correct operation it is recommended to perform programs of length corrections in weaving tests with intended yarns.



Max 5 400 RPM



6,7 kg



Min 5° C - Max 40° C



Max 85 %



Sound power L_{wa} 82.7 dB (A)
Sound pressure L_{pa} 70.5 dB (A)



Ø max 5 mm



Input air pressure 5,5 - 7 bar



290V DC, 24V DC



1,4 kg

NOTE

Subject to technical modifications.

Installation

NOTE

Condensation will form on the unit when moved from cold surroundings to the damp heat of the weaving shed. Wait at least 4 hours at room temperature before connecting to power supply.

Feeders must be mounted within 40° of the horizontal plane.

Recommended feeder bolt torque is 45 Nm.

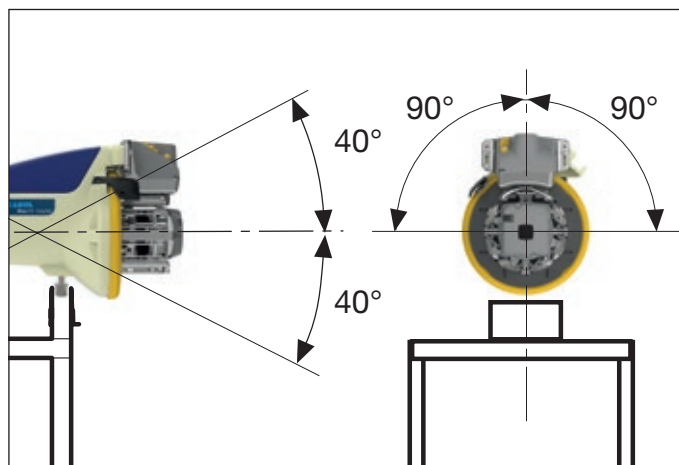

Mains Connection



WARNING

Turn off the main switch before any work is carried out on the electrical circuit.

The power supply to the feeder must not be disrupted when the weaving machine stops.

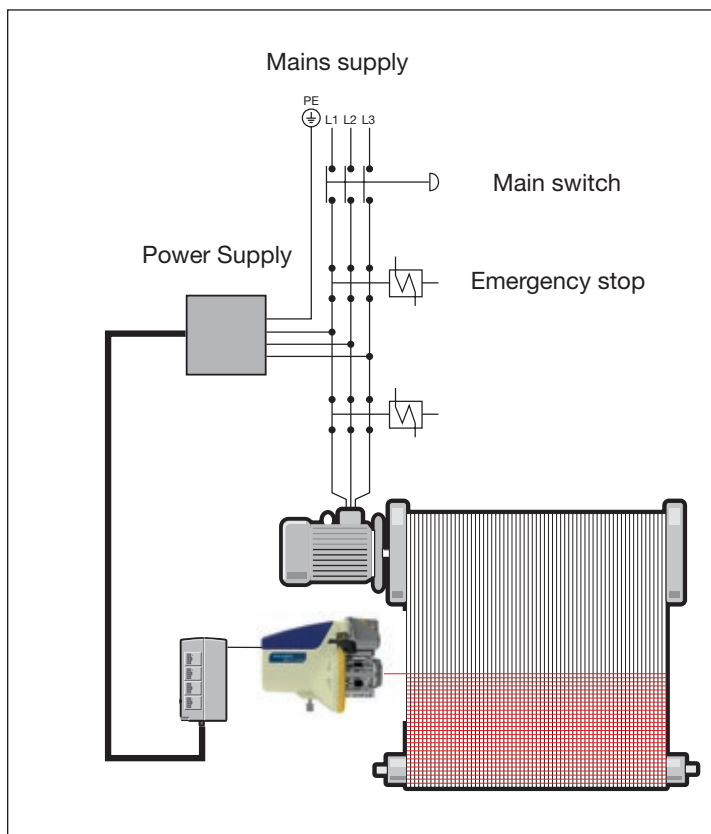
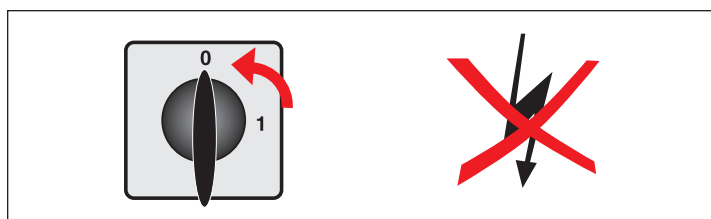

Handle and carry the feeder carefully to avoid mechanical damage and/or personal injuries.

NOTE

Do not expose the spool body parts to external forces as this may displace the finger position. Do not, for instance, push/pull fingers or carry the feeder by holding mentioned parts.

NOTE

Do not expose the winding disc to mechanical force at any time. Store the feeder resting on the back to avoid damaging/deforming the winding disc.

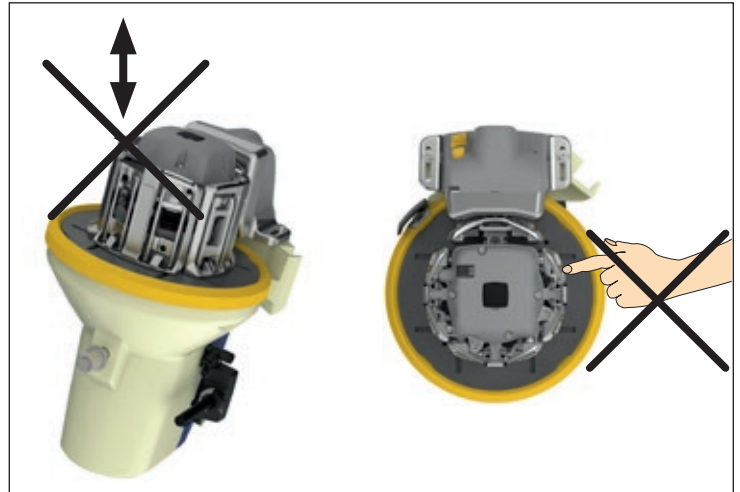

Operating diagram

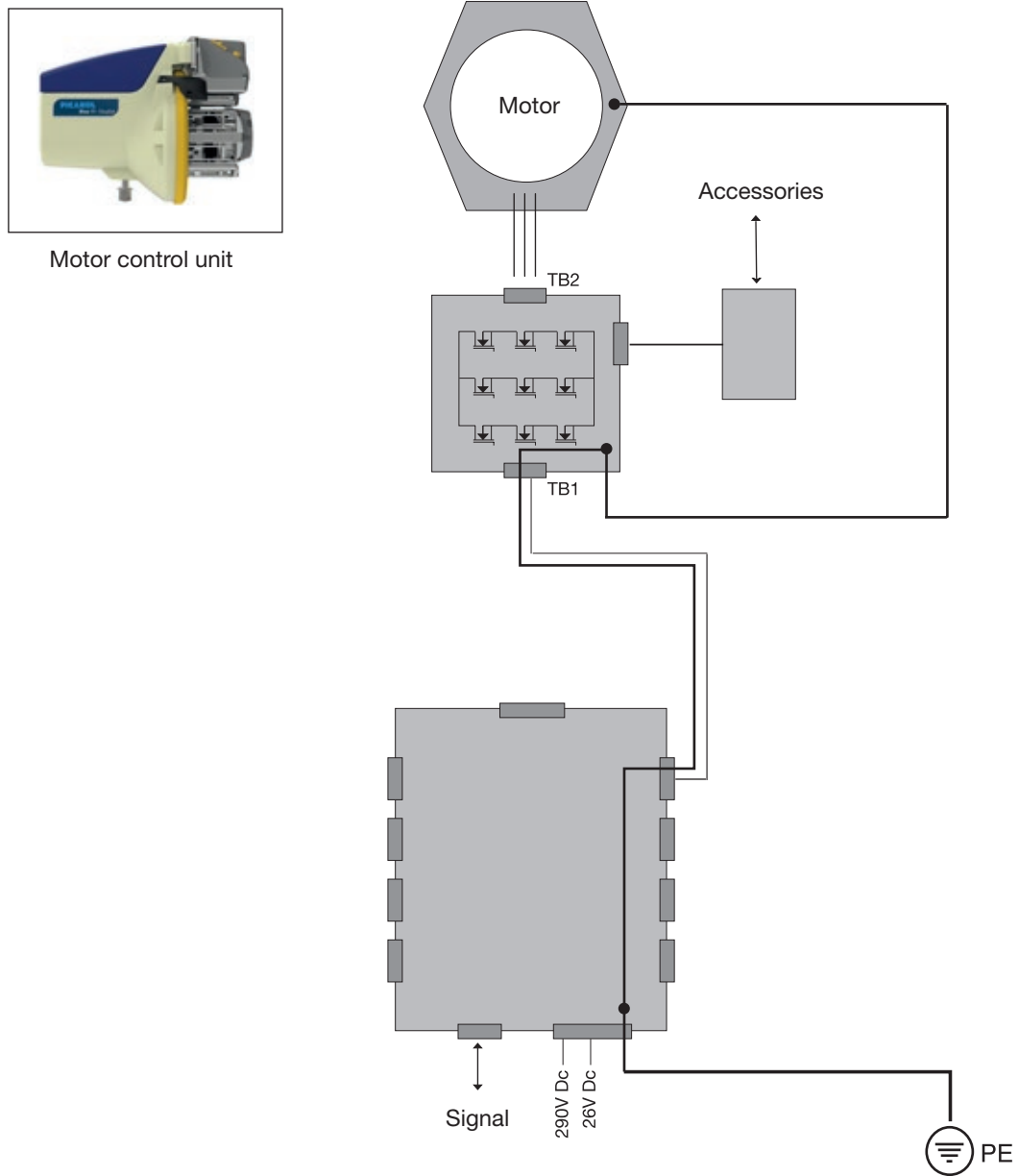

Connection diagram feeder pneumatics

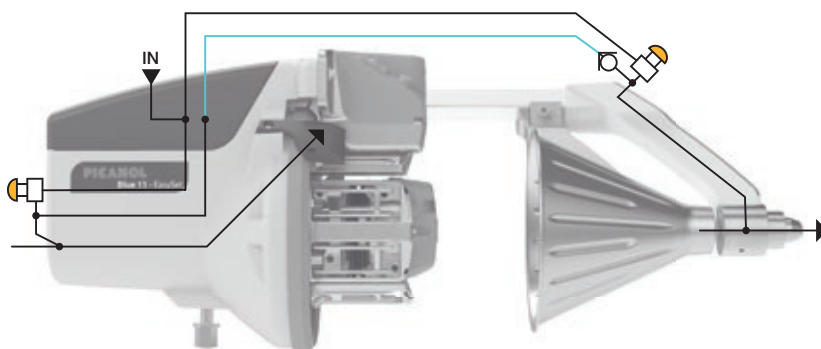



Interface
Power supplied via loom

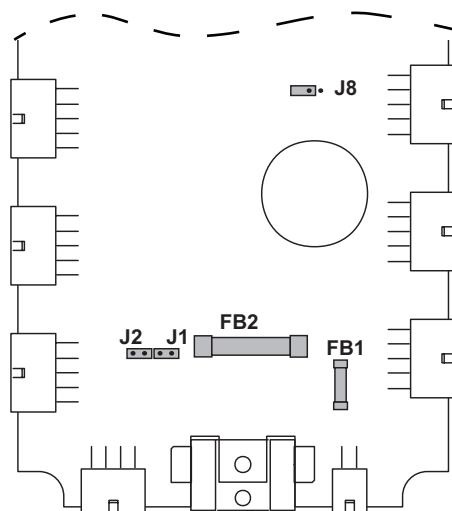

Fuses	
FB1	T 5 A
FB2	T 3,15 A

Stop relay jumpers	
J1 + J2	Open = PICAN bus not terminated Closed = Picanol bus terminated
J8	Normally open

SYSTEM

The system consists of feeders, cables to each feeder, interface control box, PTU (pneumatic threading up), input yarn tensioners and external accessories such as bobbin break sensors and bobbin change detectors.

INTERFACE

This control box handles all communication between feeders and machine via the CAN-bus system. The control box also distributes 290 VDC and 24VDC from the machine to each feeder.

FEEDER

The feeder consists of:

- Motor and control unit
- Spool body with synchronous adjustable fingers
- Pick length control stopper magnet
- Yarn store sensor
- Winding sensor
- Bobbin break sensor

All settings, including setting of the spool body circumference, are carried out on the weaving machine terminal and transmitted to the feeder through the CAN bus.

The permanent magnet motor is controlled from the control board situated under the top cover.

At feeder start-up, the size of the yarn store on the spool body is controlled by the yarn store sensor. The number of windings supplied to the yarn store is continuously counted whilst at the same time the number of windings removed from the yarn store is counted by the winding sensor. For optimal regulation the pattern information is transferred to each feeder a few picks in advance.

The weft length is equal to the spool body circumference multiplied with number of windings removed during one insertion.

The stopper magnet pin is opened at a requested machine-angle by reading the anglebus and closed directly after the second last winding sensor pulse. The stopper magnet is driven in both directions electrically, but held in closed position after the power is switched off.

Blue11 EasySet

ELECTRONIC SPOOL BODY CIRCUMFERENCE

The spool body circumference is set electronically on Blue11 EasySet. Please refer to loom settings manual for further information. Always remove spool body yarn store before adjusting spool body circumference.

NOTE

Always perform a spool body homing action at installation and every time loom power has been switched off/on to secure correct spool body circumference.

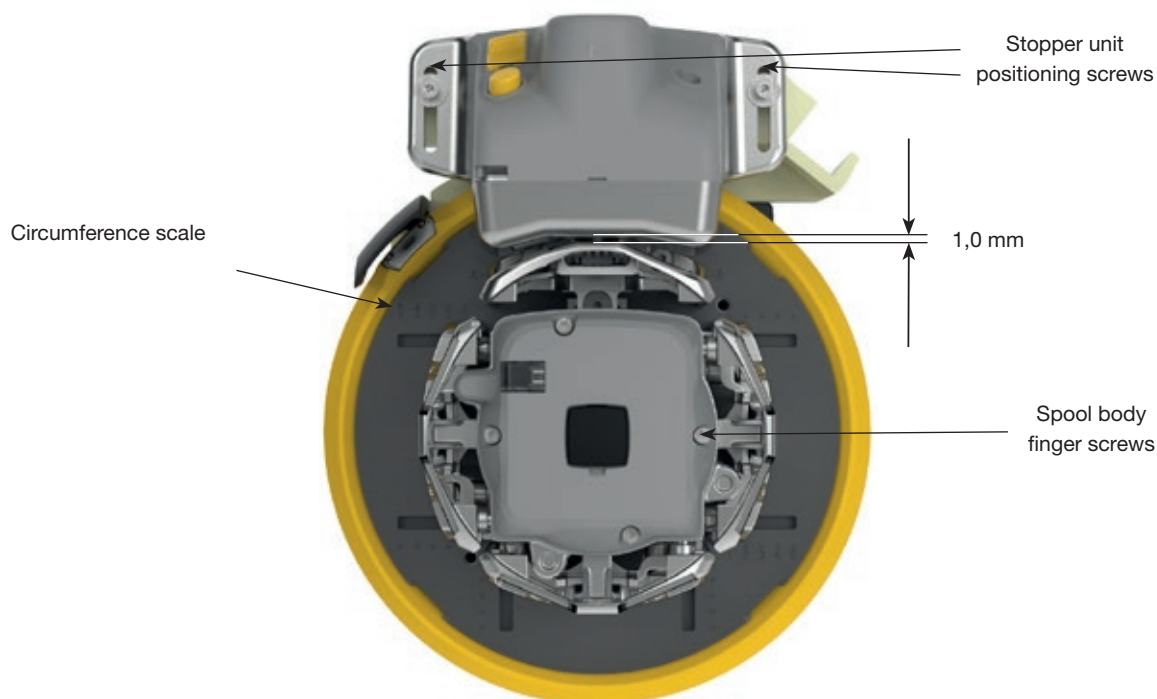

CAUTION

Beware of the moving spool body fingers during adjustment of drum circumference. Caution must be taken to avoid injury caused by moving parts.

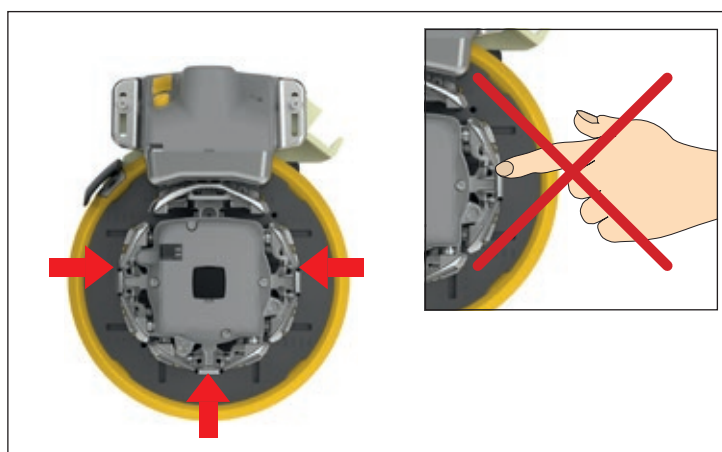

MANUAL ADJUSTMENT OF MAGNET FINGER POSITION

The automatic weft insertion length calculation system, integrated in the loom, sets the spool body diameter electronically. The required position (A & B) of the magnet finger and magnet tumbling is presented on the loom panel. Check that the fingers are set as requested. If needed change the finger positions as per instructions below.

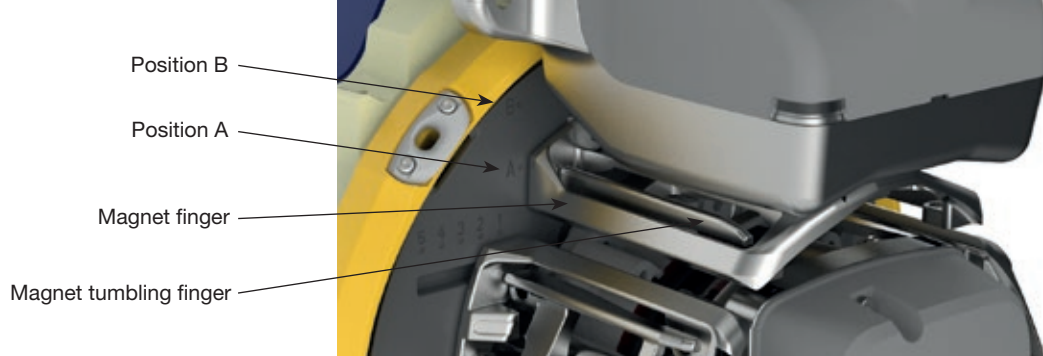

MOVE FINGERS BETWEEN POSITION A AND B

Loosen screws retaining the stopper housing and push the stopper housing upwards to the top position.

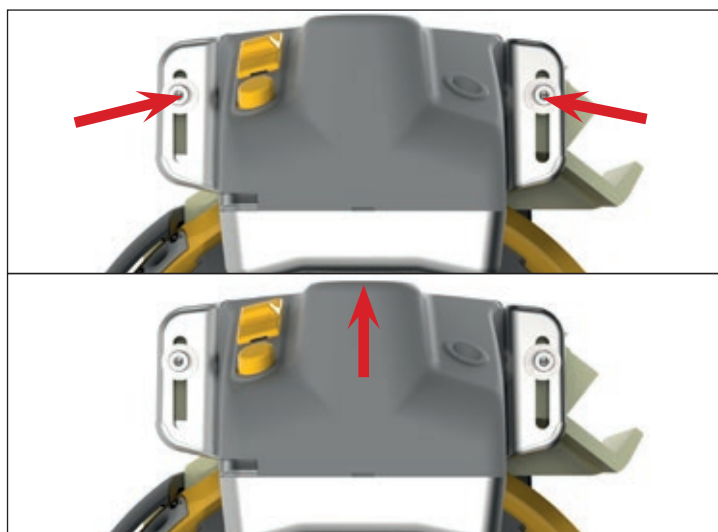

Remove screws retaining the magnet finger (2 screws) and the magnet tumbling finger (1 screw).



Move magnet finger and magnet tumbling finger to the requested position (A is the lower position and B is the upper position) and tighten the screws.

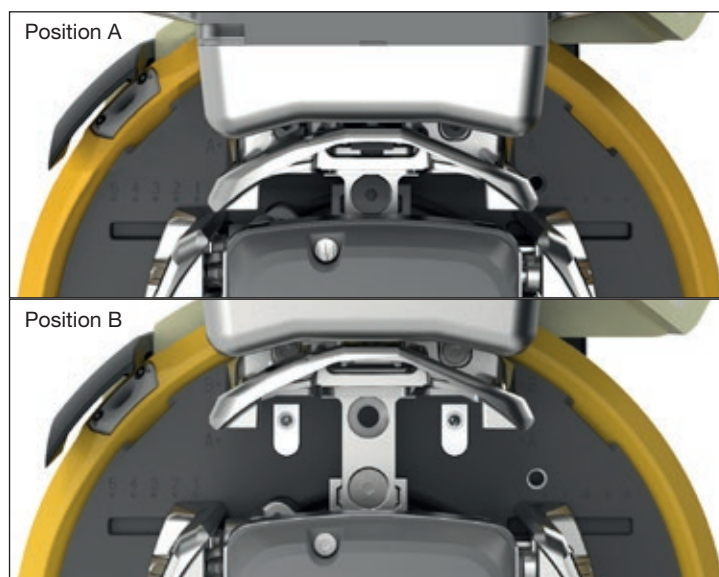

Readjust the stopper housing position. Use the adjustment guide to set correct distance between the stopper housing and the magnet finger and tighten the screws.

NOTE

Press the stopper housing towards the motor flange while tightening the screws in order to secure the correct distance between the stopper housing and the magnet finger.

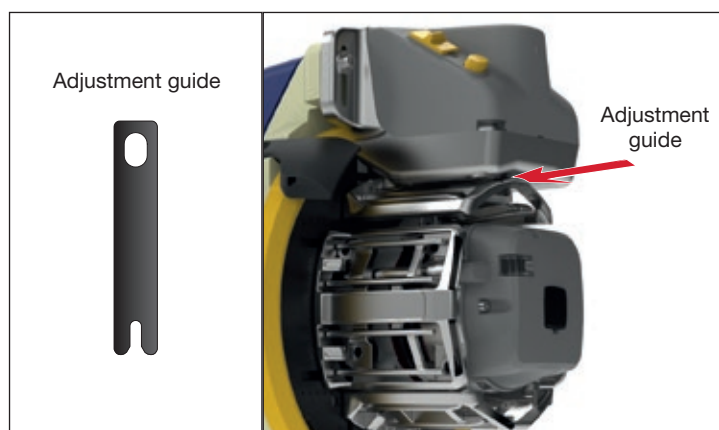

Side view

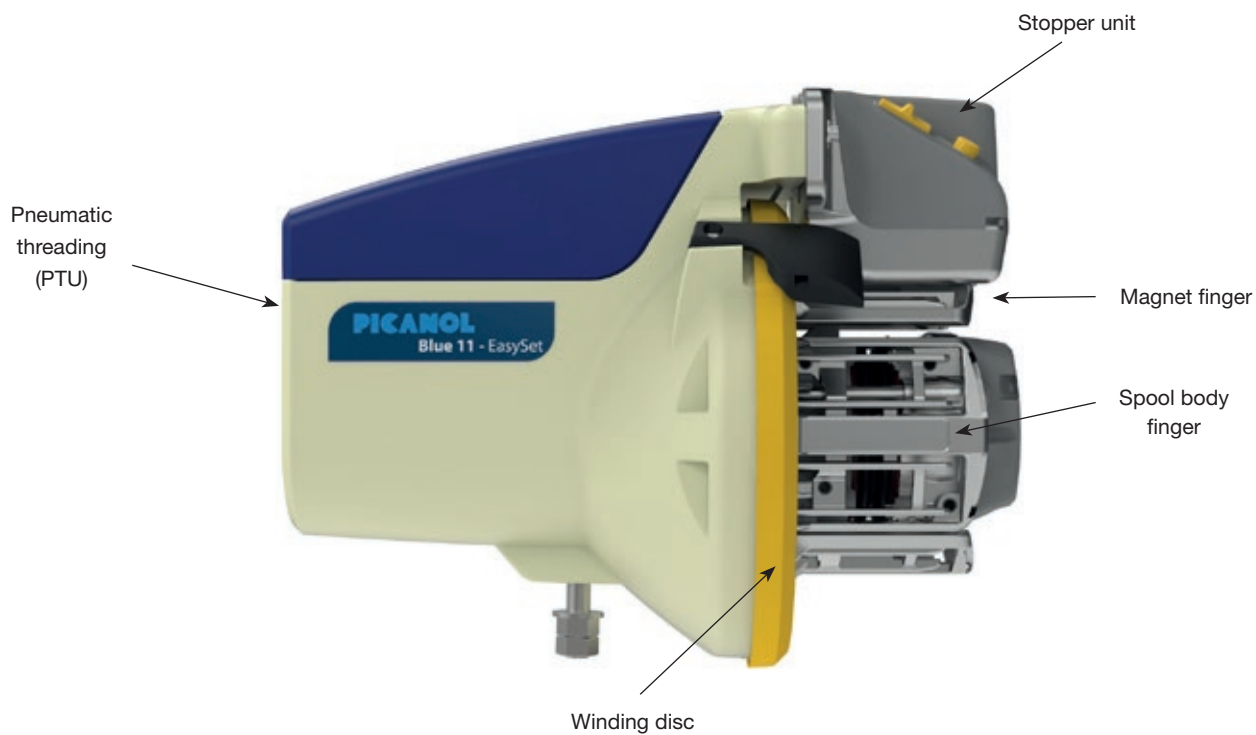

Front view

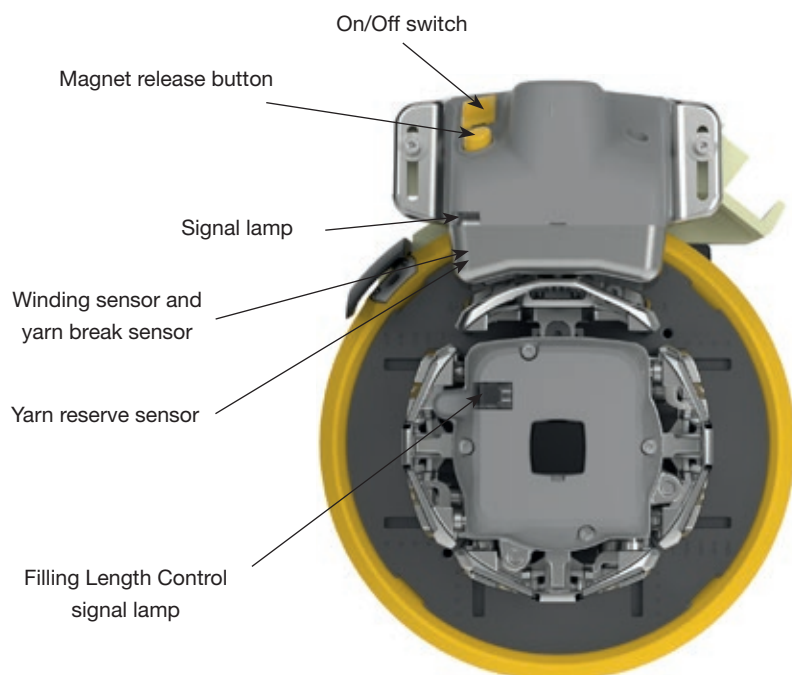

Balloon control

To ensure optimal yarn performance between the feeder and the weaving machine it may be beneficial, especially when weaving heavier yarns, to use a cone for balloon control. During the initial installation the cone should be adjusted to the outermost position, then, with the machine running, slide the cone inwards towards the feeder until the optimum yarn path is obtained. The cone should then be locked into position.

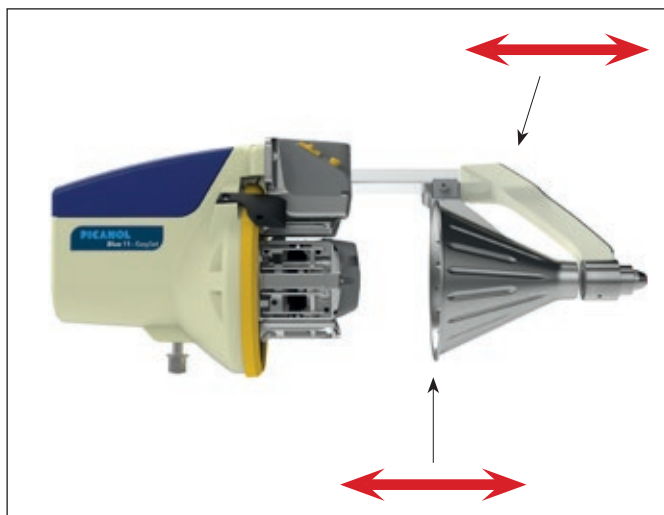
Threading

Before threading the feeder it is necessary to remove any yarn that may be on the spool body. To do this the magnet pin must be opened. This can be performed using any of the following methods:

- A short push on the yarn release button will release one winding.
- or
- By pushing the yarn release button and keeping it pushed the magnet pin will remain open as long as the button is pushed.

After the magnet pin has been opened any yarn on the spool body can be removed.

TO THREAD THE UNIT PROCEED AS FOLLOWS: *

1. Hold the end of the yarn close to the input eyelet at the rear of the feeder.
2. Push the PTU activating button and release the yarn.
3. Take hold of the yarn end.
4. Reset the feeder (switch off/on).

* = Full threading: Ensure that the yarn eyelet is correctly positioned under the guide (A).

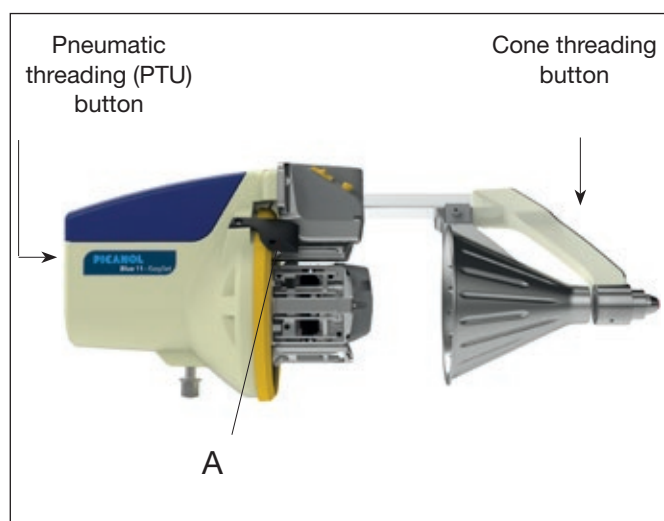

 **WARNING**

Failure to follow these instructions will result in damage to the spool body, stopper magnet, stopper magnet pin or the stopper housing

With feeder connected to the weaving machine and machine power on.
Switch off the feeder.

Press the button on the stopper housing and ensure that the magnet pin retracts. The spool body can be rotated as long as the button is activated.

With feeder removed from the weaving machine OR when the power to the weaving machine is switched off. Remove the two screws retaining the stopper housing.

Remove the stopper housing completely. The spool body can now be rotated as necessary.

When reassembling the stopper housing it will be necessary to adjust the distance between the magnet and the magnet finger (B) using the stopper housing adjustment guide (A).

NOTE
Press the stopper housing towards the motor flange while tightening the screws in order to secure the correct distance between the stopper housing and the magnet finger.

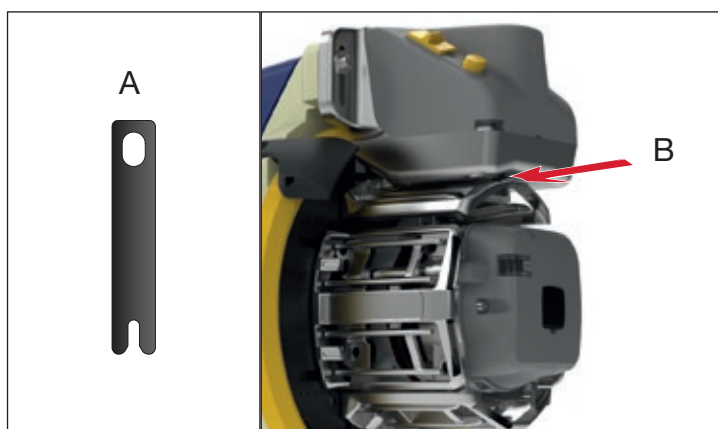
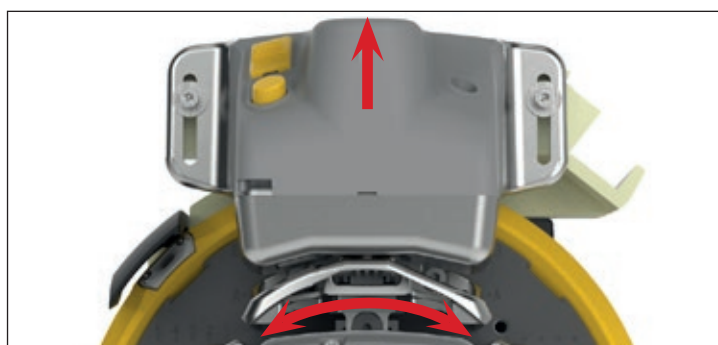
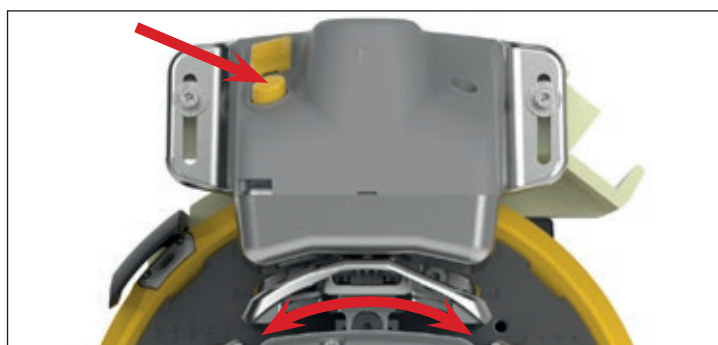

CLEANING

It is recommended to carry out a periodical cleaning of any lint or dust accumulation on the feeder or the control box.

NOTE

DO NOT use compressed air when cleaning the feeder.

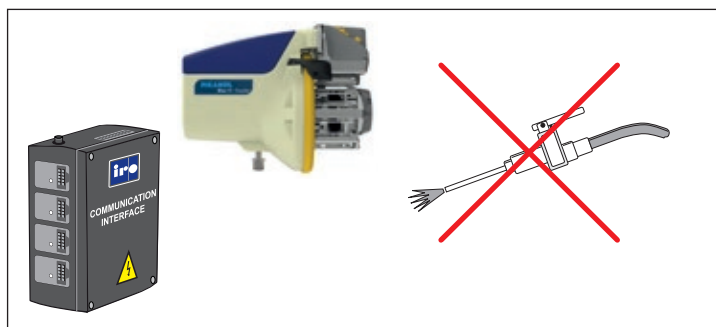

LUBRICATION

The unit requires no extra lubrication.

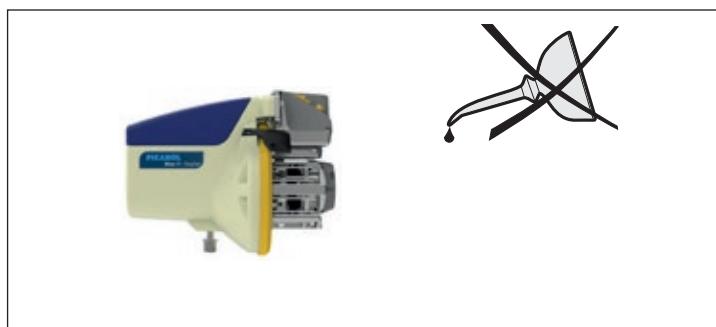

CONNECTIONS

NOTE

The connector cover must be assembled.

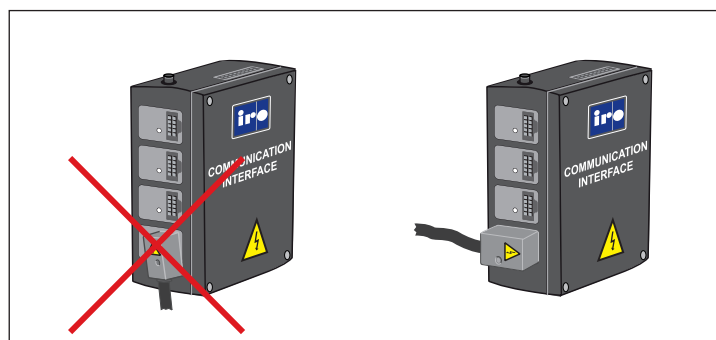

IRO TOOL KIT

Use the proper IRO tool kit, with specialised tools, to ensure easy and correct disassembly/assembly of IRO feeders during maintenance work. Please contact your local IRO service station for further information.

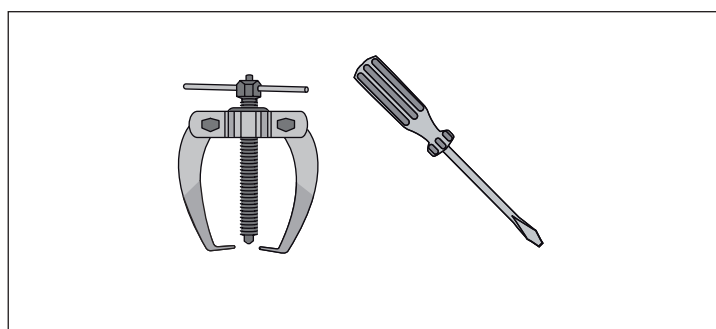

Fault	Check in the following order
Feeder motor does not start when ON/ OFF switch is ON - Feeder LED Off.	9, 13, 15, 23, 21, 17, 19, 20, 14
Feeder motor does not start when ON/ OFF switch is ON - Feeder LED On.	1, 3, 12, 23, 16
Feeder LED indicates error (double blinking).	10, 11, 12, 13, 14, 17, 20, 19, 21
Feeder LED indicates error (blinking).	24
Feeder stopper magnet does not open.	10, 11, 23, 17
Input yarn breaks frequently.	8
Feeder does not fill up yarn properly.	1, 3, 7, 8, 16
Feeder does not stop (over filling).	3, 1, 16
Loom terminal indicates "Blocked rotor".	12, 8
Communication failure between loom and feeder.	15, 16, 17, 19, 20, 21
Frequent problems with long or short picks.	2, 7, 8, 16, 22
Feeder indicates bobbin break but the yarn is not broken.	2, 22, 16, 29
Feeder does not stop at yarn break.	4, 5, 6, 2, 22, 16
Spool body diameter adjustment fails	25, 26, 27
Spool body LED keep blinking continuously after diameter adjustment	30, 28, 8, 25, 26

No	Possible causes	Remedies
1.	Feeder not clean	Remove dust and fibres, clean sensor window
2.	Sensor not clean	Remove dust and fibres, clean sensor window and mirror
3.	Wrong reserve sensor settings	Adjust sensor sensitivity settings (loom terminal)
4.	Yarn break sensor not activated	Activate yarn break sensor (loom terminal)
5.	Yarn break sensor not connected	Connect yarn break sensor
6.	External sensor selected, but not installed	Select "internal" yarn break sensor (loom terminal) or install external sensor
7.	Input yarn tension too low	Adjust input tensioner
8.	Input yarn tension too high	Adjust input tensioner
9.	Loom "main power" and "stand by" off	Switch loom "main power" and "stand by" on
10.	Stopper magnet not connected	Check that the magnet connector is properly connected to the circuit board
11.	Stopper magnet failure	Check magnet coil resistance with Ohm-meter
12.	Rotor blocked	Check if the winding disc rotates freely
13.	Feeder motor not connected	Check that the motor connector is properly connected to the circuit board
14.	Feeder motor failure	Check stator resistance with Ohm-meter
15.	Sensor board not connected	Check that the sensor board connector is properly connected to the circuit board
16.	Sensor damaged	Replace sensor
17.	Motor circuit board damaged	Replace motor circuit board
18.	Fuses blown - Feeder	Check fuse. If broken, replace circuit board
19.	Interface board damaged	Replace interface circuit board
20.	Fuses blown - Interface	Check fuse. If broken, replace fuse or circuit board
21.	Power failure 290V / 24V DC failure.	Check interface and feeder fuses, check voltage level
22.	Incorrect distance between fixed finger and stopper unit	Adjust gap to 1 mm
23.	Switch failure	Replace stopper housing cover
24.	Yarn break indication	Rethread feeder
25.	Spool body motor not connected	Connect spool body motor
26.	Spool body motor damaged	Replace drive suspension (with motor)
27.	Coils damaged	Replace coils
28.	Spool body out of position	Perform a spool body reset diameter action
29.	Wrong yarn break sensor setting	Adjust settings in case of External YBS
30.	Spool body not emptied	Empty spool body before adjustment action

Bobbin Switch Sensor

SYSTEM DESCRIPTION:

Compact Sensor designed for integration in the CAN communication system. It is designed to give an instantaneous, reliable indication of bobbin switch-over, allowing the weaving machine to take the appropriate measures. The BSS is extremely simple to install.

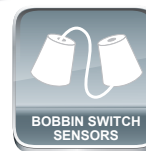

INSTALLATION

Make sure that the loom main power has been switched off.

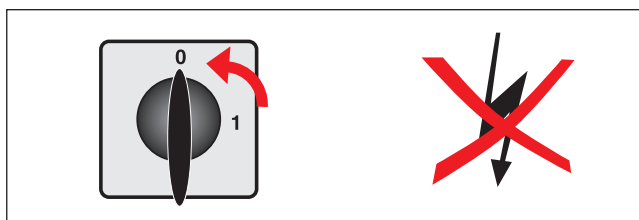

Disassemble the circuit board housing from the feeder.



Plug in the cable on the circuit board (red arrow marks the connector).

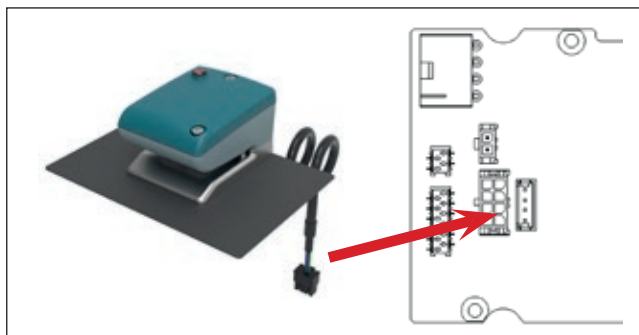

Position the cable as shown then re-assemble the circuit board housing onto the feeder.



Multi yarn break sensor system

SYSTEM DESCRIPTION:

The Multi yarn break sensor system makes it possible to use multiple weft sensors on the feeders. The sensors will detect possible yarn breakage on the feeder input side.



The central box (concentrator box) has connectors for feeders (4 connectors) and external yarn break sensors (8 connectors).

PARTS:

The system consists of one concentrator box, power supply cable, extension cables and sensors.

POSSIBLE COMBINATIONS FEEDERS - SENSORS:

Number of feeders	Number of yarn break sensors per feeder:
1	0-8
2	0-4
3	0-2
4	0-2

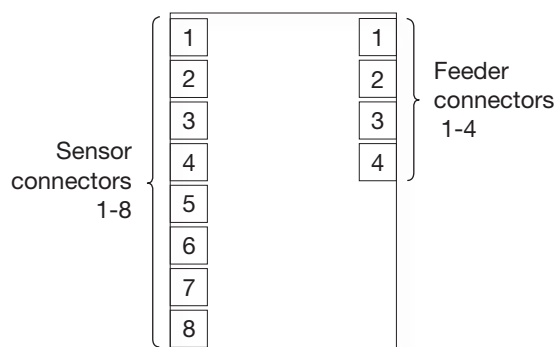

INSTALLATION

Carefully follow instruction below for a secure installation. Picture on page 21 explains the numbers mentioned in the instruction. Appendix 1 & 2 show where to connect the sensors and feeder cables to the concentrator box.

- A. Make sure that the loom main power has been switched off.
- B. Fixate the concentrator box (3) to the feeder stand. Use the supplied screws (length M5x50).
- C. Fixate the external yarn break sensors with tensioner* (5) on the bobbin creel (one sensor per yarn).
- D. Open the cover of the concentrator box and connect the extension cable (2) between the external break sensors and the concentrator box. One extension cable per sensor must be used.

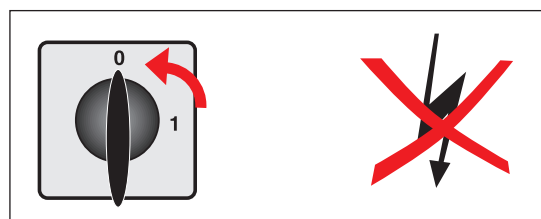

It is important that the extension cables are connected to the correct connector in the concentrator box. Use appendix 1 & 2 as a guide.

NOTE
The cable has a label telling that the connector should be connected to the concentrator box, and not to the feeder.

* The tensioner is not indicated in the picture on next page

Multi yarn break sensor system

E. Connect the signal cable (4) between the feeder (7) and the concentrator box. It is important that the signal cable is connected to the correct connector in the concentrator box.

F. Connect the power supply cable (1) between the feeder interface box (6) and the concentrator box. Use the connector on the upper side of the feeder interface (see picture below). Use the power supply connector in the concentrator box as illustrated on page 22.

G. Turn on loom main power.

H. Choose external yarn break sensor on the feeder setting page on the weaving machine control panel.



Disassemble the circuit board housing from the feeder.

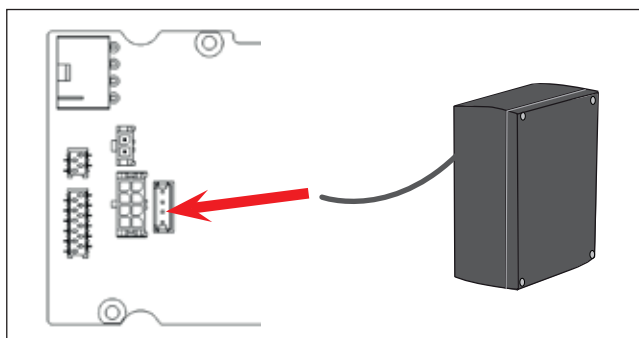

Plug in the cable on the circuit board (red arrow marks the connector).



Position the cable as shown then re-assemble the circuit board housing onto the feeder.

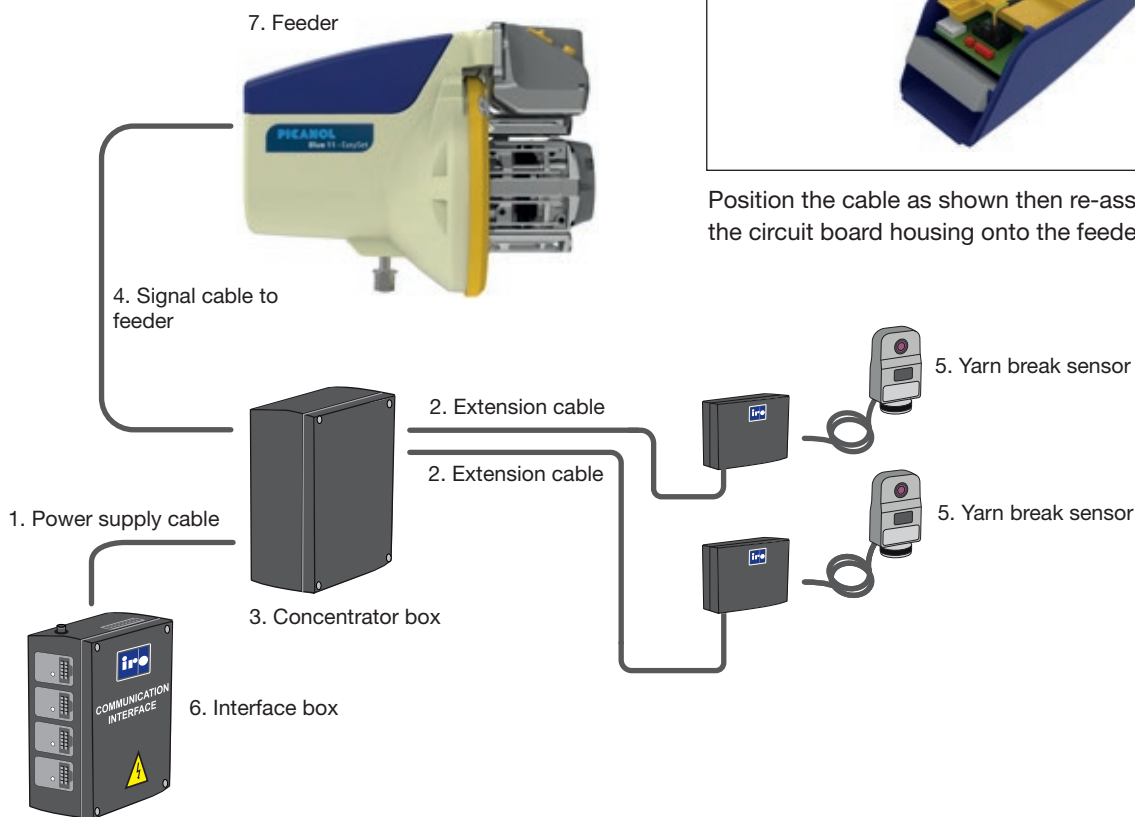

Multi yarn break sensor system

Appendix 1 - Concentrator box circuit board connectors

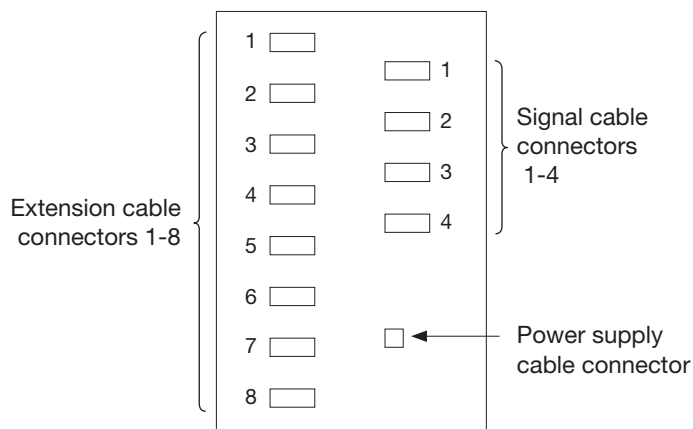

Appendix 2 - Connection of feeders and sensors in Concentrator box

