

Ref. no. 40-8939-2001-05/2038

Operating Instructions

LUNA X3, CHRONO X3, XD X3, XD X3 PLUS, HD X3

EN |

Original language instruction

Warnings	3	Threading - pneumatic	
Technical specifications	4-5	Luna X3, Chrono X3, XDX3	23
Mains connection	6	Threading - manual	
Operating diagram		Luna X3, Chrono X3, XD X3, XD X3 Plus	24
Luna-X3, Chrono-X3, XD-X3	7	Threading - pneumatic and manual	
Connections power supply/ interface		HD X3	25
Luna-X3, Chrono-X3, XD-X3	8	Sensor adjustment	
Connections interface		Luna X3, Chrono X3, XD X3, XD X3 Plus	26
Luna-X3, Chrono-X3, XD-X3	9	HD X3	27
Operating diagram		Tension settings/ Balloon control.....	28
XD X3 Plus, HD X3	10-11	Relaxing ramps	
Connections heavy duty power supply		XD X3, XD X3 Plus, HD X3	29
XD X3 Plus, HD X3	12	Tensioners: Brush	30
Connections heavy duty power supply CAN		Tensioners: Flex Brake/ Lamella	31
XD X3 Plus, HD X3	13	Tensioners: Brush/ Flex Brake	32
Connections power supply/ interface	14	Tensioners: TEC	33
XD-X3	14	Tensioners: CAT	34
Installation		Tensioners: Balloon adjustment.....	35
Luna-X3, Chrono-X3, XD-X3	15-16	Tensioners: Funnel	36
Jumpers		Assembly instructions	
XD X3 Plus, HD X3	17	Chrono X3, XD X3, XD X3 Plus, HD X3	37
Speed settings - feeders with mechanical sensors	18	Maintenance.....	38-39
Main parts		Fault finding	
Luna-X3, Chrono-X3, XD-X3	19	Luna X3, Chrono X3, XD X3	40
XD X3 Plus	20	XD X3 Plus	41
HD X3	21	HD X3	42
S/Z Adjustment	22	Declaration of conformity	43

This section contains important safety information. Read the manual carefully before installing, using or maintaining the weft feeder.



WARNING

Indicates a possible dangerous situation which could result in serious injury or damage to the unit.



CAUTION

Indicates a possible dangerous situation which could result in minor/moderate injury or damage to the unit.

NOTE

Used in order to draw attention to important information, which facilitates operation or handling.

IRO AB reserve the right to change the contents of the user's guide and technical specifications without prior notification.

**WARNING!**











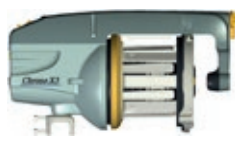
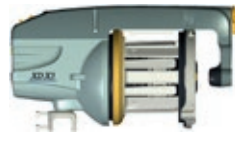







- The power supply must be switched off at the mains before any work is carried out on the feeder, the transformer/interface or any other electrical components. The feeder and the transformer cabinet and cable covers must be fully assembled before the power supply is connected.
- The weft feeder ON/OFF-switch **DO NOT** cut off the main power supply. Turn off the main switch before any work is carried out on the electrical circuit.
- The feeder and transformer contain electrical components that retain an electric current up to three minutes after disconnection. **DO NOT** open or disconnect feeder or interface, including cables, within this time.
- All work on electrical components must be carried out by a qualified electrician.
- This product is not intended for use in potentially explosive atmospheres or in zones classified according to the European directive 94/9/ec. Please contact IRO AB if products for use in a potentially explosive atmosphere are required.
- Always turn off the main switch or isolate the power supply and disconnect the air supply before connecting or disconnecting the feeder, the control board or any of the circuit boards
- Routine checks for damaged or worn parts must be made before operating this equipment. Any part that is worn or damaged should be properly repaired or replaced by authorized personnel. To avoid risk of injury **DO NOT** operate this equipment if any component does not appear to be functioning correctly.
- Take necessary precautions to avoid injuries when interacting with the product. Use suitable respiratory and eye protection.
- Improper handling at repair, fault finding or similar may damage the feeder/interface mechanical/electrical components including cables and connectors. **DO NOT** perform measurements on feeder electrical components and parts. Please contact your local IRO AB service station for further information.

**CAUTION!**

- Caution must be taken in the close vicinity of the feeder as it contains moving parts that can cause injuries and, in normal operation, starts without prior warning.
- To comply with C.E. Regulations only replacement parts approved by IRO AB may be used.
- The feeder is an industrial product and therefore not approved to use household environments /in residential areas.

NOTE

- To ensure the selection of the most suitable feeder and associated accessories, it is recommended making weaving tests with the intended yarns.
- Please dispose of obsolete or unwanted equipment responsibly, taking into consideration any local regulations regarding the disposal and / or recycling of materials that are applicable.
- All products in this manual may not be available for your market.
- The performance of a tensioner can be affected by various factors connected to the specific yarns being used. In case of uncertainty it is recommended to carry out a weft insertion test.

	Luna X3	Chrono X3	XD X3
			
	Max 1800 m/min	Max 1800 m/min	Max 1800 m/min
	6.5 kg	8.6 kg	8.6 kg
	Min 5° C - Max 40° C	Min 5° C - Max 40° C	Min 5° C - Max 40° C
	RH max 85 %	RH max 85 %	RH max 85 %
	Sound pressure L_{pa} 74 dB (A), Sound power L_{wa} 88 dB (A)	Sound pressure L_{pa} 74 dB (A), Sound power L_{wa} 88 dB (A)	Sound pressure L_{pa} 74 dB (A), Sound power L_{wa} 88 dB (A)
	Ø max 5 mm	Ø max 5 mm	Ø max 5 mm
	Input air pressure 5,5 - 7 bar	Input air pressure 5,5 - 7 bar	Input air pressure 5,5 - 7 bar
	Max 2,7 mm	Max 4 mm	Max 4 mm
Power Supply/ Interface			
		200 - 575V 400VA	200 - 575V 400VA
	 Fuse	Max T 10A	Max T 10A
		3,3 kg	3,3 kg
Interface			
		Power supply via loom/ weaving machine	Power supply via loom/ weaving machine
		1,4 kg	1,4 kg
Extension Interface			
		Power via Power Supply/ Interface connected to extension plug	Power via Power Supply/ Interface connected to extension plug
		1,4 kg	1,4 kg

NOTE

Subject to technical modifications.

WARNING!

Hearing protection must be worn when operating this equipment.

	XD X3 Plus	HD X3	
	Max 1600 m/min	1600 m/min	
	11,5 kg	12,8 kg	
	Min 5° C - Max 40° C	Min 5° C - Max 40° C	
	RH max 95 %	RH max 95 %	
	Sound pressure L_{pa} 67,1 dB (A), Sound power L_{wa} 79,5 dB (A)	Sound pressure L_{pa} 67,1 dB (A), Sound power L_{wa} 79,5 dB (A)	
	Ø max 11 mm	Ø max 11 mm	
	Input air pressure 5,5 - 7 bar	Input air pressure 5,5 - 7 bar	
	Max 4 mm	Max 4 mm	
Heavy Duty Power Supply Stand Alone			
		230-575V 1000VA	230-575V 1000VA
		Max T 10A	Max T 10A
		21 kg	21 kg
Heavy Duty Power Supply CAN			
		380-440V 1900VA	380-440V 1900VA
		Max T 10A	Max T 10A
		35 kg	35 kg

NOTE

Subject to technical modifications.

WARNING!

Hearing protection must be worn when operating this equipment.

NOTE

Condensation can form on the weft feeder when it is moved from the cold environment of the warehouse to the warmer environment of the loom room. Make sure that the feeder is dry before switching it on.



WARNING!

Turn off the main switch before any work is carried out on the electrical circuit.

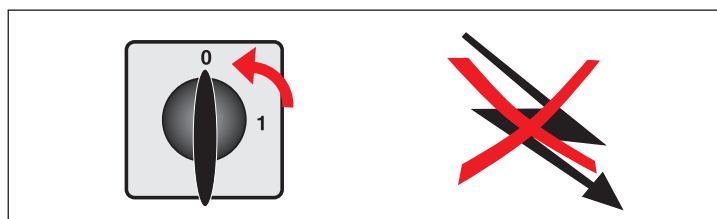

NOTE

Make sure that the cable covers are tight.



Take the Voltage Supply Box out of the packing. Open the cover and connect the three-phase power cord. (4-wires cable). Make sure that the earth connection is properly made. The section of each wire cannot be less than 1,5 mm².

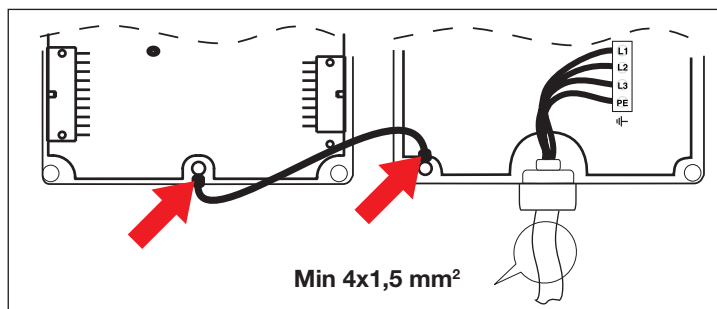

The power supply to the feeder must not be disrupted when the weaving machine stops.

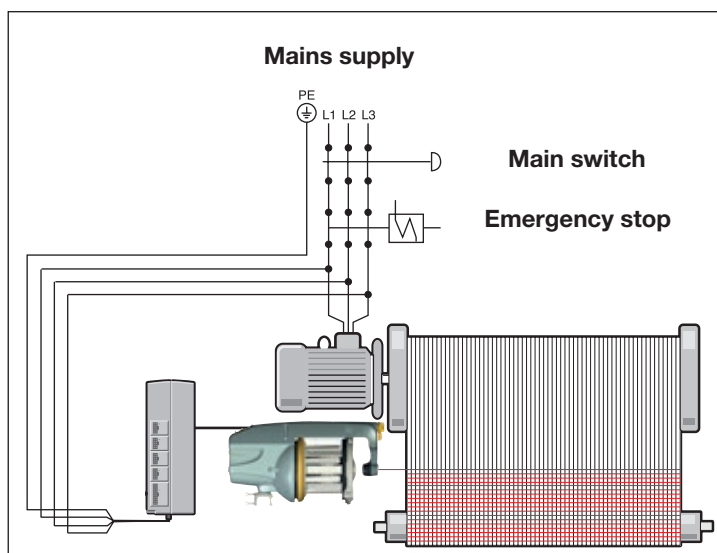

Variations in main voltage.

 VOLT +/- 10%		
Nominal	Voltage	Frequence
200V - 346V	180V - 380V	50/ 60 Hz
380V - 400V	342V - 440V	50/ 60 Hz
415V - 575V	374V - 632V	50/ 60 Hz

Luna-X3, Chrono-X3, XD-X3

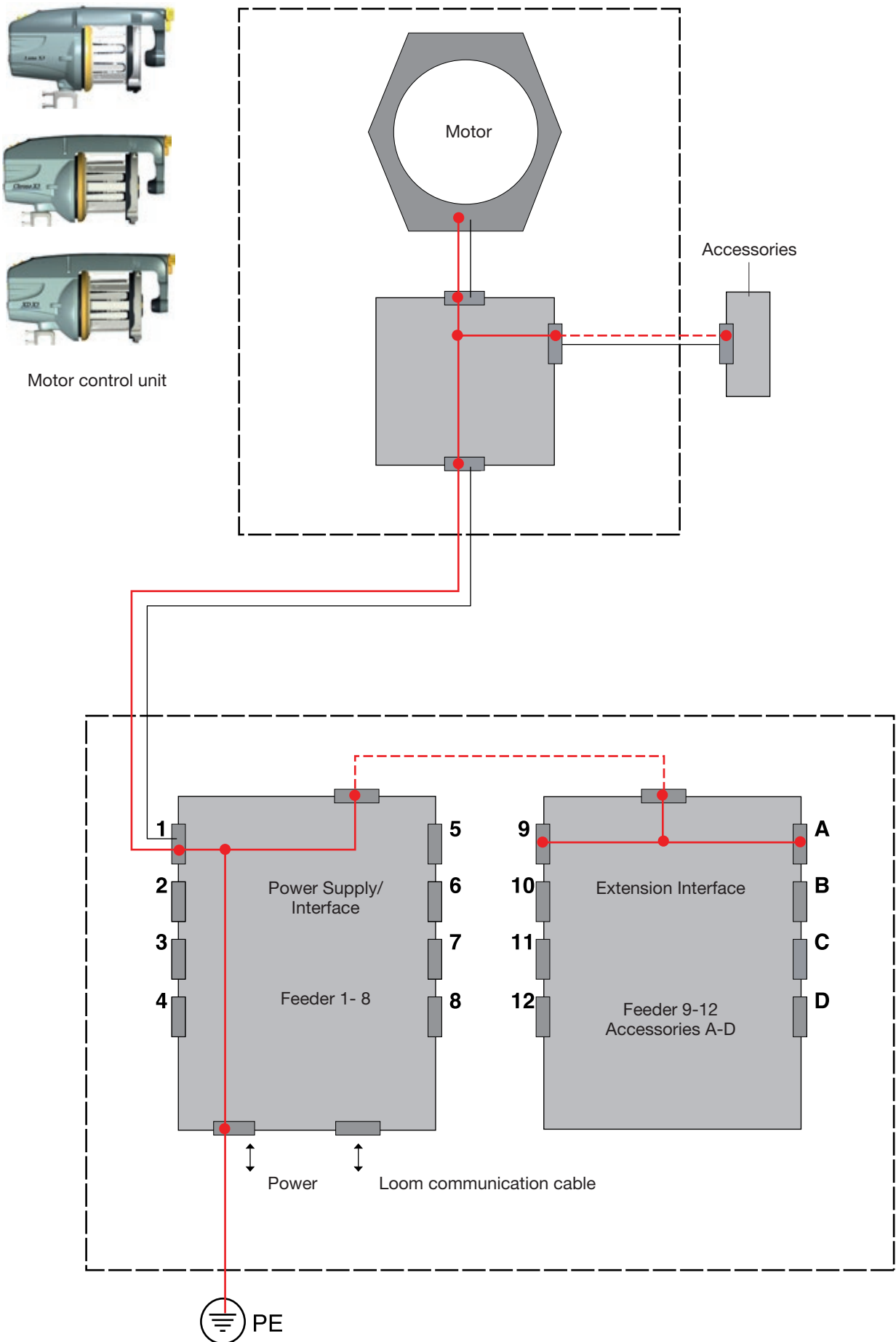

Luna-X3, Chrono-X3, XD-X3



Power Supply/ Interface

Mains connection

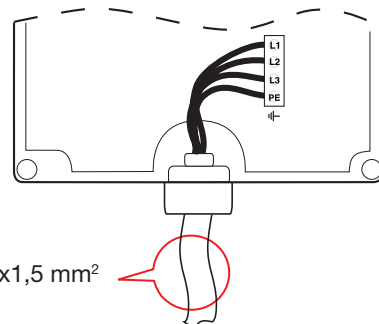

CAN - INTERFACE

Fuses

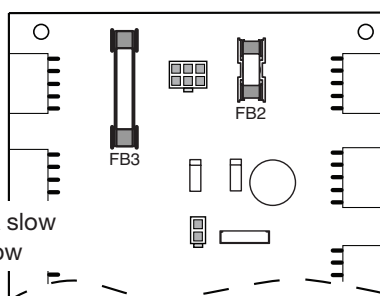

STAND ALONE - INTERFACE

Fuses

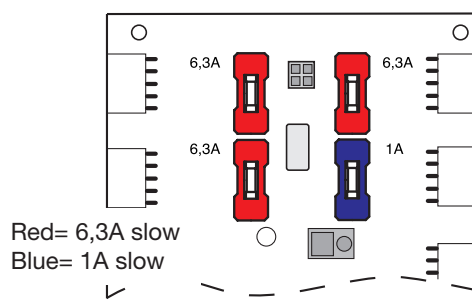

Stop relay jumpers

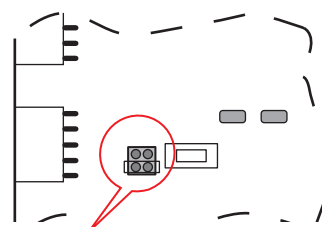

- NO - normally open
- NC - normally closed
- Without stop relay signal

Opto coupler/ stop relay connection

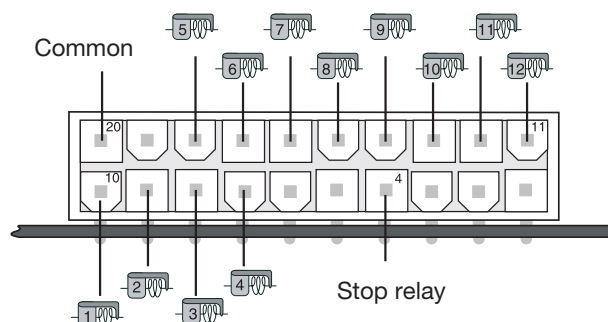

Luna-X3, Chrono-X3, XD-X3



Interface
Power supplied via loom

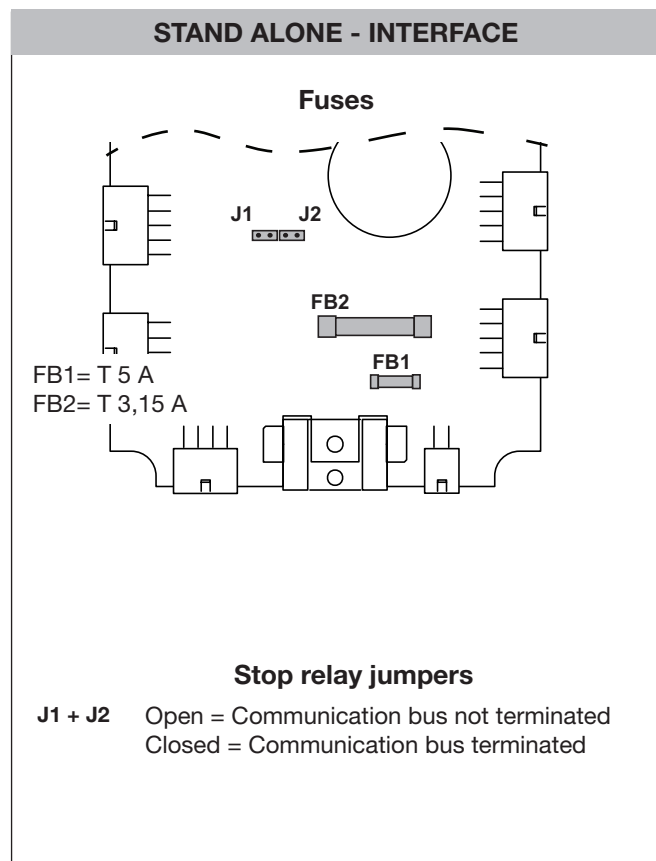
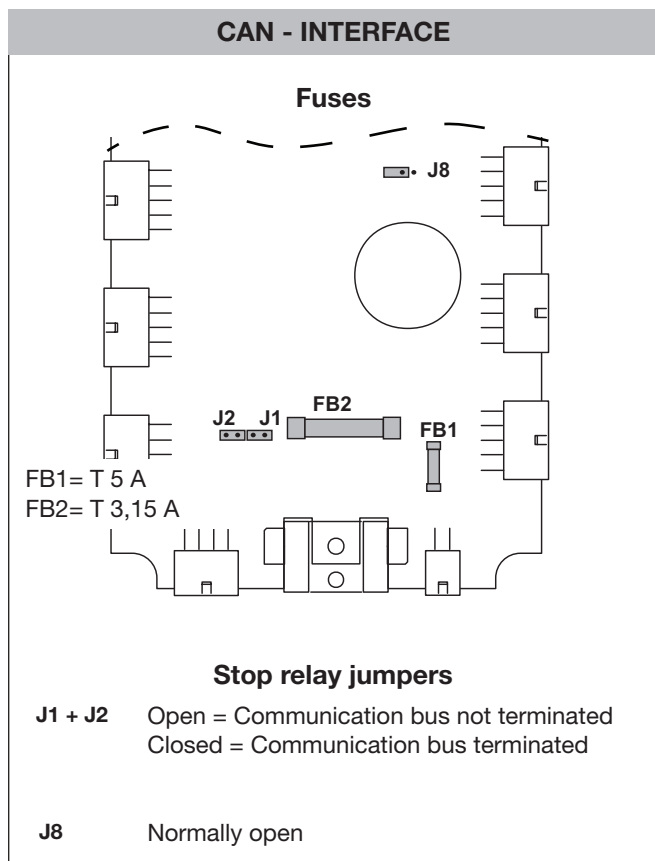

XD X3 Plus, HD X3

Connect the feeders' cable to the voltage supply box by following the numeric correspondence to the color selector's needles.

NOTE

Feeder working with the weft threaded in the needle 1 must be connected to the position 1 of the voltage supply box; etc.

Connect the signal cable coming from the voltage supply box to the loom.

Connect the plug of the 3-phase power cord to the socket available to the loom panel.

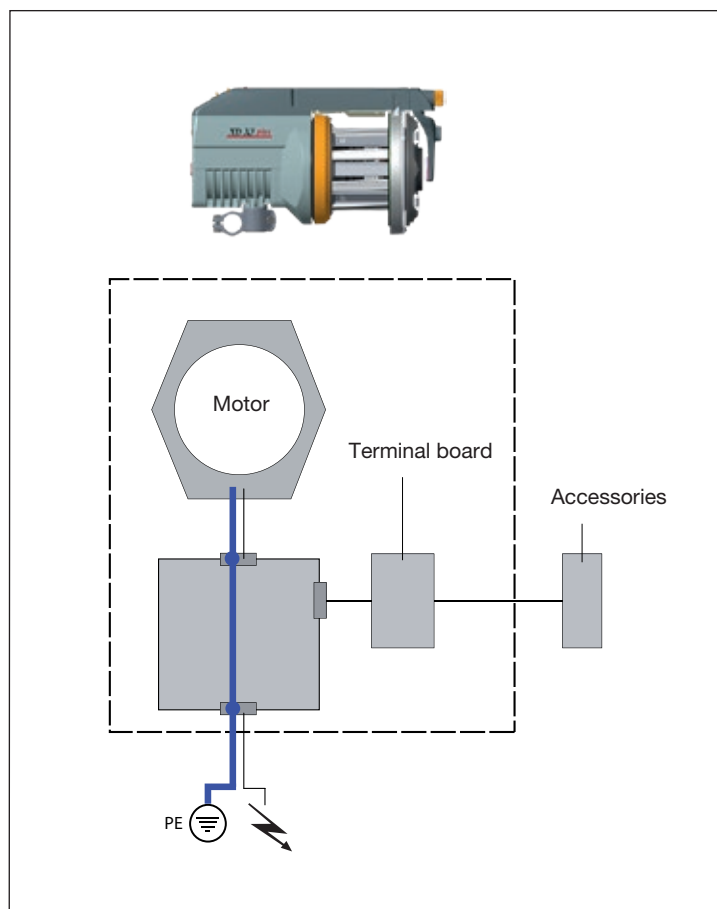

HD X3

**HD POWER SUPPLY /
CAN INTERFACE**

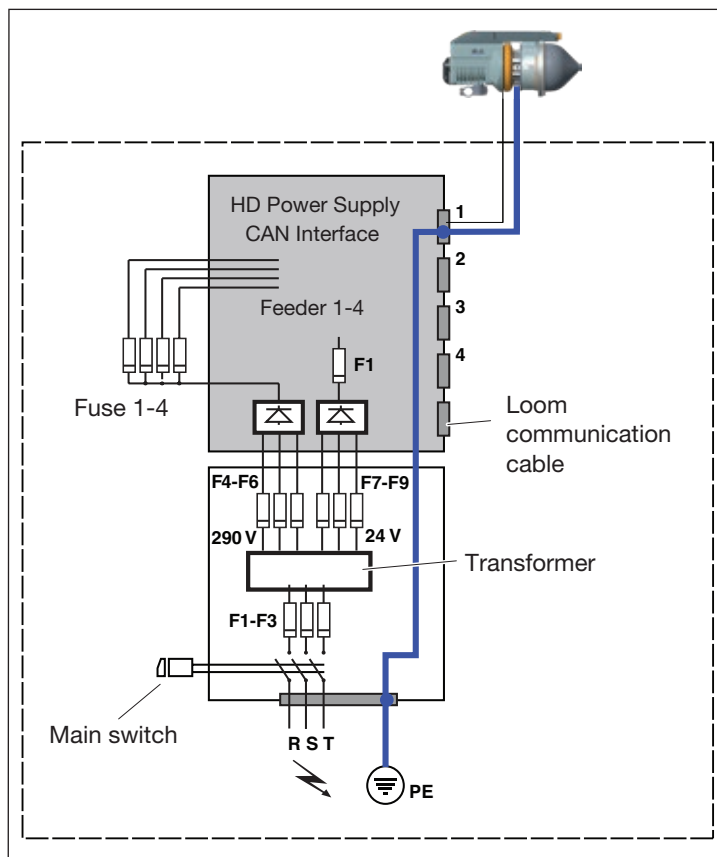

XD X3 Plus, HD X3

**HD POWER SUPPLY /
STAND ALONE INTERFACE**

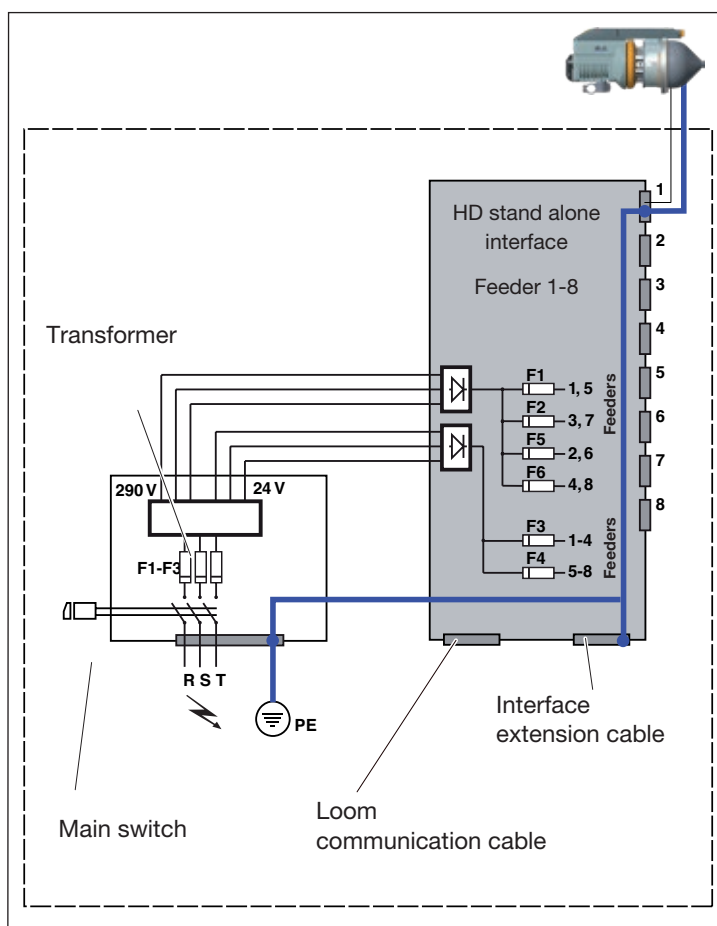

XD X3 Plus, HD X3

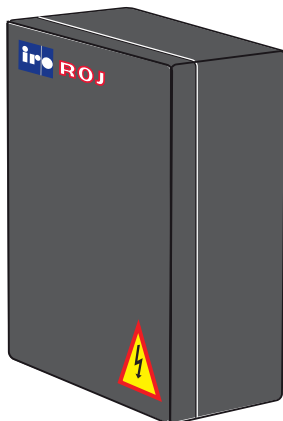

Heavy Duty Power Supply Stand Alone

STAND ALONE - POWER SUPPLY

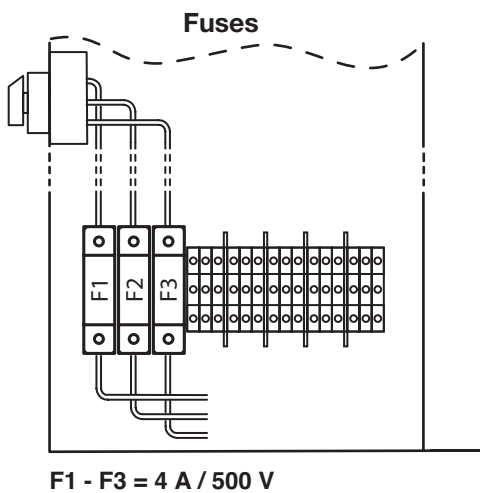

Mains connection

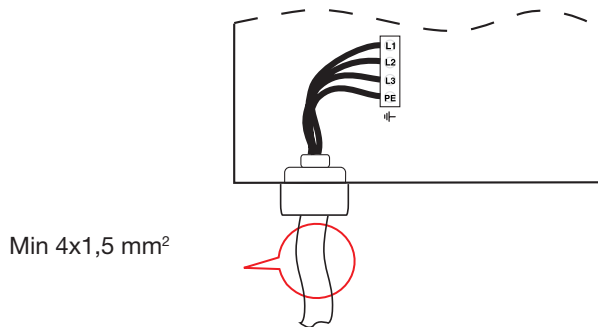

STAND ALONE - INTERFACE

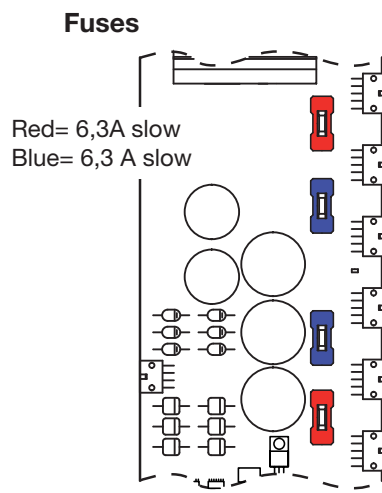

Stop relay jumpers

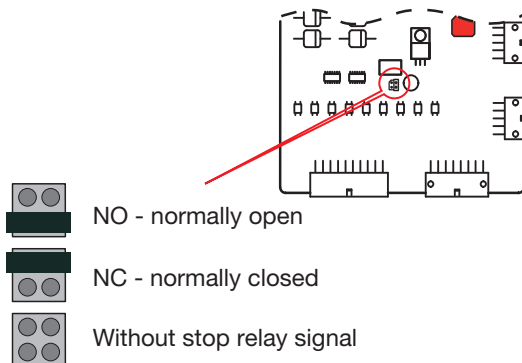

Opto coupler/ stop relay connection

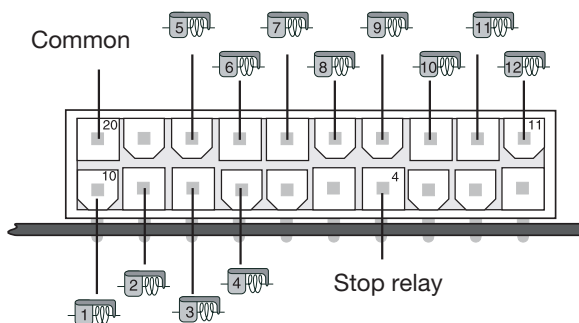

XD X3 Plus, HD X3

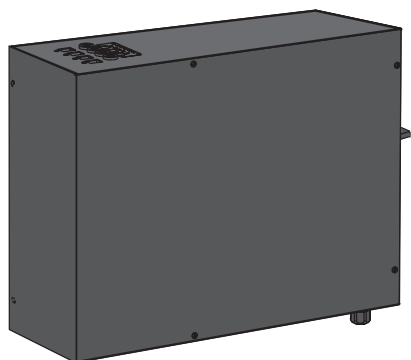

Heavy Duty Power Supply CAN

Mains connection

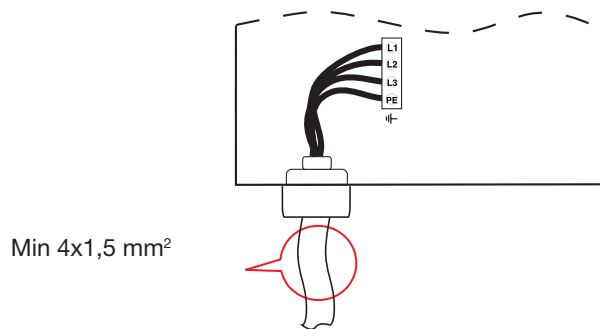

CAN - POWER SUPPLY

Fuses

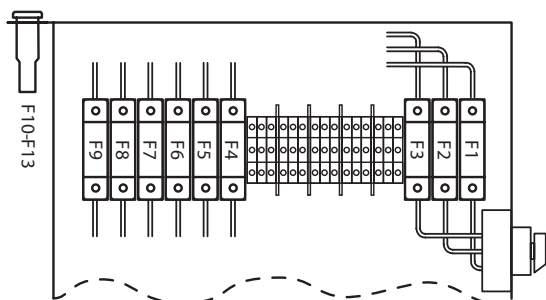

F1 - F6 = 10 A / 500 V
 F7 - F9 = 4 A / 500 V
 F10 - F13 = 8 A / 500 V

CAN - INTERFACE

Fuses

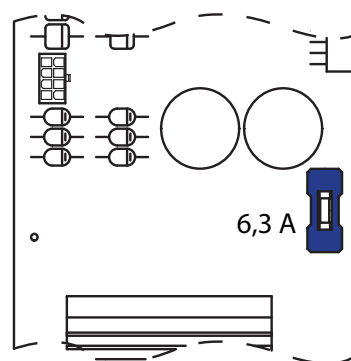

Blue= 6,3A slow

XD-X3



Power Supply/ Interface

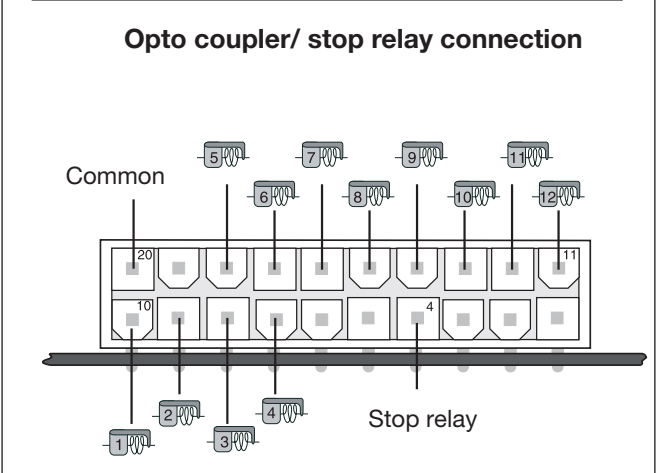
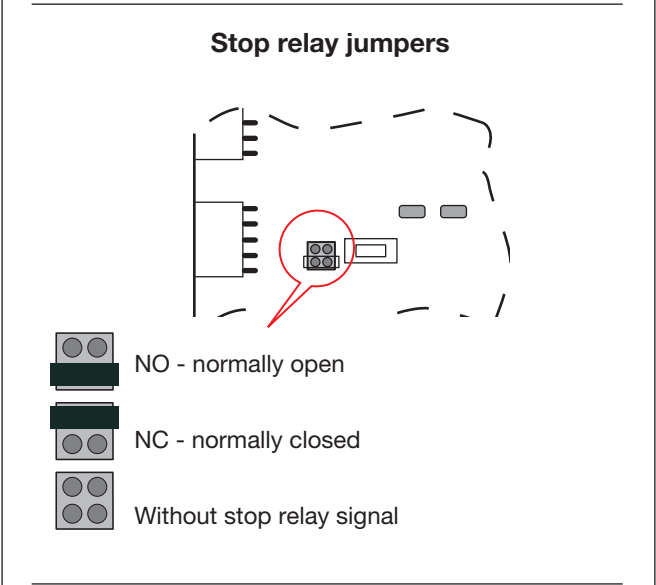
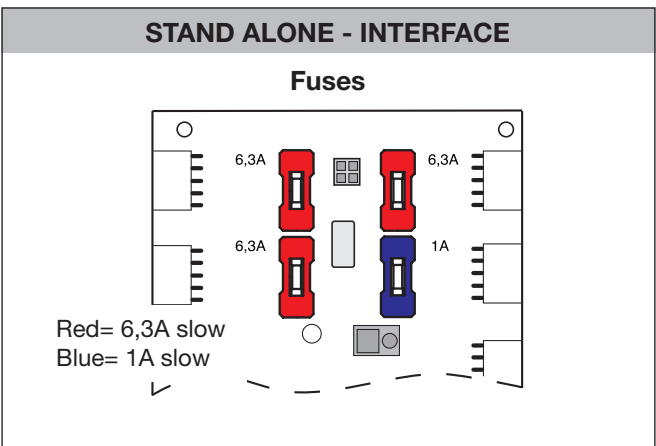
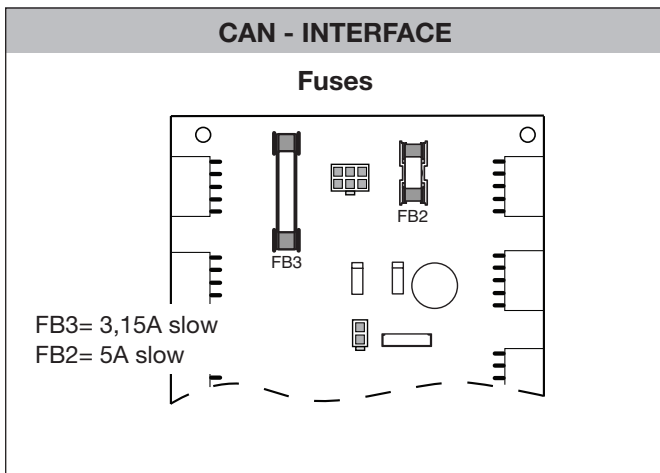
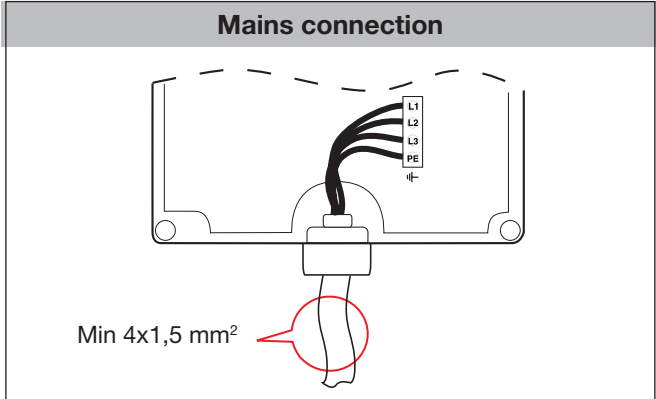

NOTE

Condensation can form on the weft feeder when it is moved from the cold environment of the warehouse to the warmer environment of the loom room. Make sure that the feeder is dry before switching it on.



CAUTION!

The unit should not be mounted directly on the weaving machine.

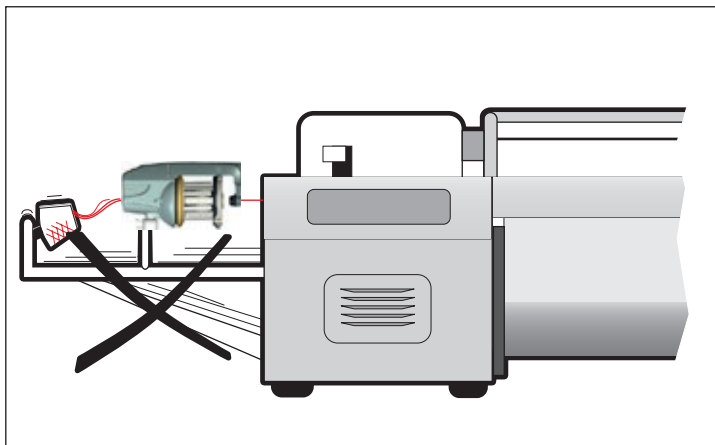

Use a separate floor stand.

NOTE

Feeders' stand and creel must be connected to the earth of the loom.

NOTE

Place the creel behind the feeder's stand avoiding sharp angles to the yarn path from the creel output to the feeders.

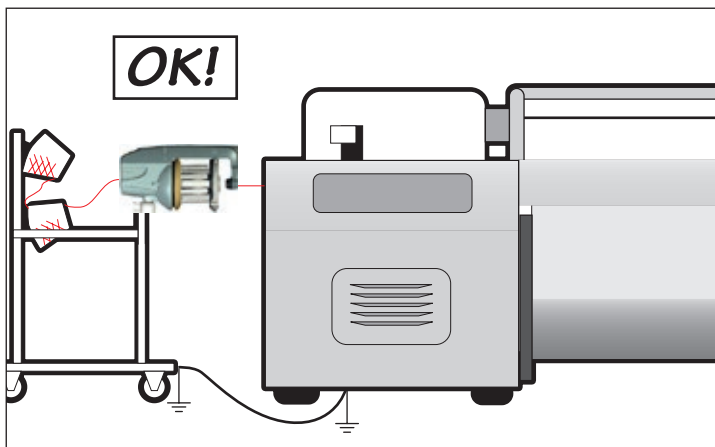

Feeders with Mechanical sensors must be mounted within 45° of the horizontal plane.

*Max 15° with low sensor spring force.(see page 26)

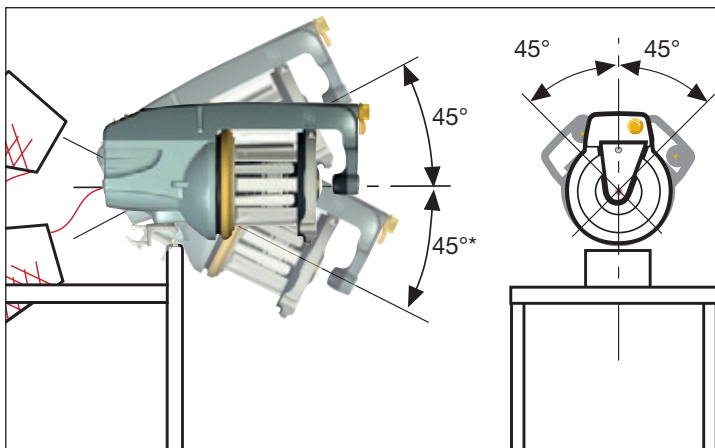

Ensure that the mount screws are correctly tightened.

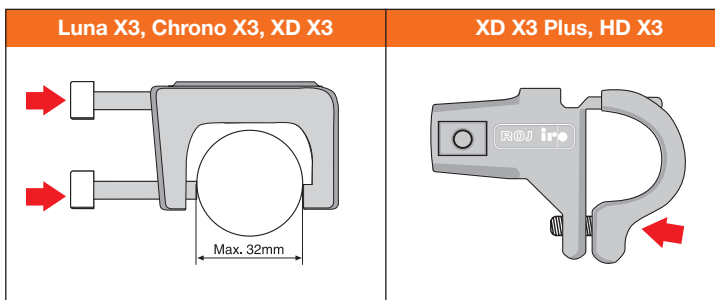

Luna-X3, Chrono-X3, XD-X3

The feeder is equipped with jumpers on the motor circuit board that adapt the feeders operation to the characteristics of the weaving process. (Weaving machine settings have priority over jumper settings).

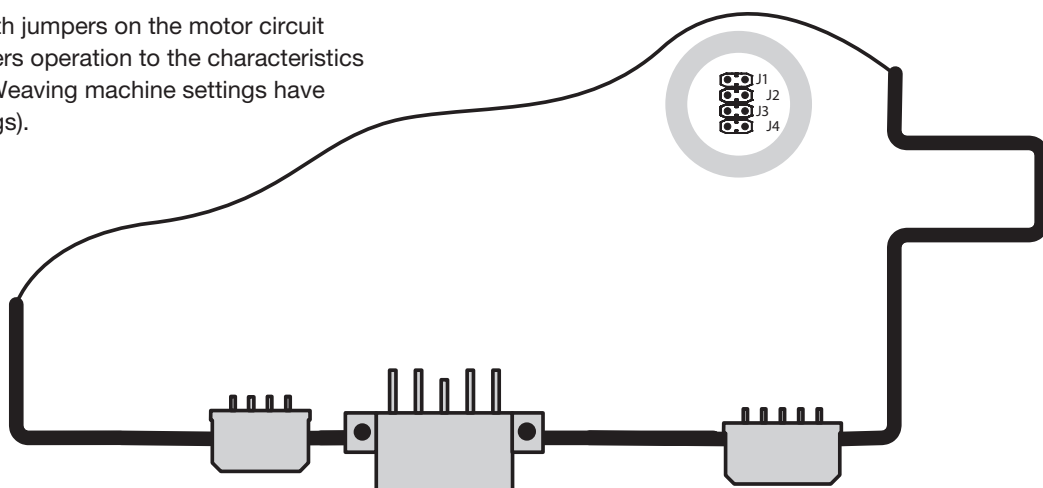







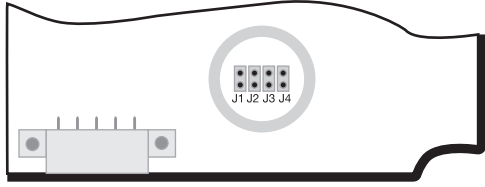
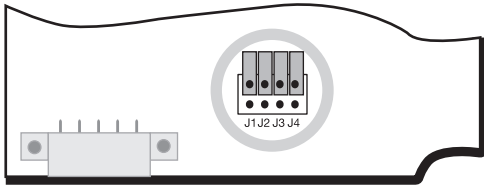

	Opto sensors
J1	Yarn store sensor sensitivity- LOW
J1	Yarn store sensor sensitivity- AUTO
J2	Integrated yarn break sensor- DISABLE
J2	Integrated yarn break sensor- ENABLE
J3	Winding disc positioning- DISABLE (one way bearing)
J3	Winding disc positioning- ENABLE
J4	Pattern in advance- DISABLED
J4	Pattern in advance- ENABLED

Mech. sensors
Yarn break sensor filtering- RIGID YARNS
Yarn break sensor filtering- NORMAL
Integrated yarn break sensor- DISABLE
Integrated yarn break sensor- ENABLE
Winding disc positioning- DISABLE (one way bearing)
Winding disc positioning- ENABLE
Pattern in advance- DISABLED
Pattern in advance- ENABLED

XD X3 Plus, HD X3

The feeder is equipped with jumpers on the motor circuit board that adapt the feeders operation to the characteristics of the weaving process. (Weaving machine settings have priority over jumper settings).

	XD X3 Plus	HD X3
		
J1 	Yarn store sensor sensitivity- LOW (Normal setting XD X3 Plus)	-
J1 	Yarn store sensor sensitivity- AUTO	-
J2 	Integrated yarn break sensor- DISABLE	-
J2 	Integrated yarn break sensor- ENABLE	-
J3 	Winding disc positioning- DISABLE (ONE WAY BEARING)	Winding disc positioning- DISABLE (ONE WAY BEARING)
J3 	Winding disc positioning- ENABLE	Winding disc positioning- ENABLE
J4 	Pattern in advance- DISABLE	Pattern in advance- DISABLE
J4 	Pattern in advance- ENABLE	Pattern in advance- ENABLE
		<p>NOTE</p> <p>Whenever the electronic board or the sensors board are replaced, it is necessary to carry out the “Automatic sensor calibration procedure”.</p>

To set the maximum speed rotate the disc to the appropriate position.

NOTE

Normally the switch should be left at position 1 since the feeder automatically calculates the speed according to yarn consumption. However, with very low speeds or wide looms, it could be helpful to reduce the maximum speed in order to avoid unnecessary acceleration

	Luna X3	Chrono X3	XD X3
	1 = 1500 m/min 2 = 1200 m/min 3 = 800 m/min 4 = 500 m/min	1 = 1500 m/min 2 = 1200 m/min 3 = 800 m/min 4 = 500 m/min	1 = 1500 m/min 2 = 1200 m/min 3 = 800 m/min 4 = 500 m/min
	XD X3 Plus	HD X3	
	1 = 1600 m/min 2 = 1300 m/min 3 = 1100 m/min 4 = 900 m/min	1 = 1600 m/min 2 = 1300 m/min 3 = 1100 m/min 4 = 900 m/min	

Luna-X3, Chrono-X3, XD-X3

NOTE

Do not expose the brush ring holder or the winding disc to external forces as this may cause damage / deformation.

Do not, for instance, carry the feeder by holding it in the brush ring holder.

Store the feeder resting on the back or top cover to avoid damaging / deforming mentioned parts.

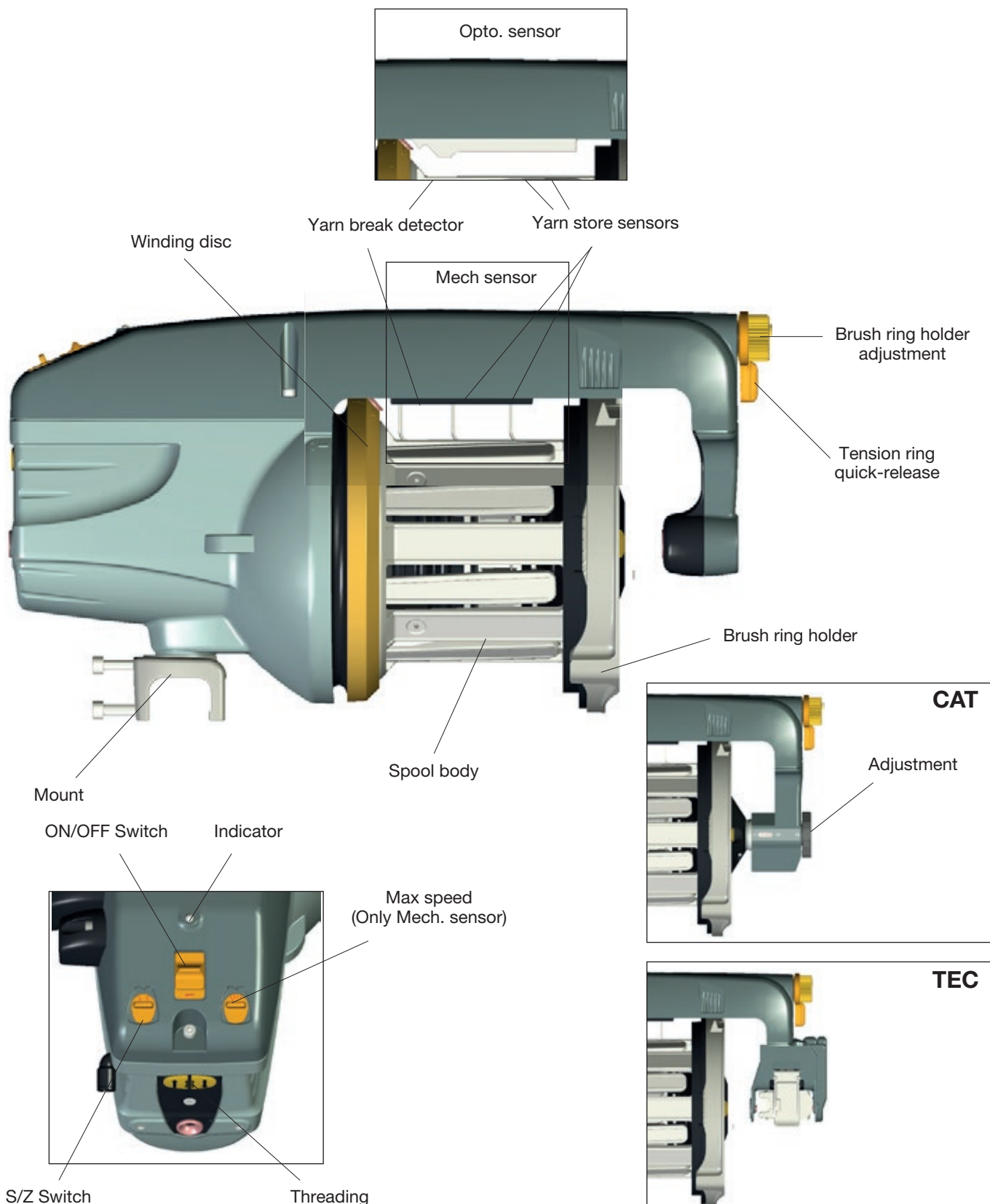

XD X3 Plus

NOTE

Do not expose the brush ring holder or the winding disc to external forces as this may cause damage / deformation. Do not, for instance, carry the feeder by holding it in the brush ring holder. Store the feeder resting on the back or top cover to avoid damaging / deforming mentioned parts.

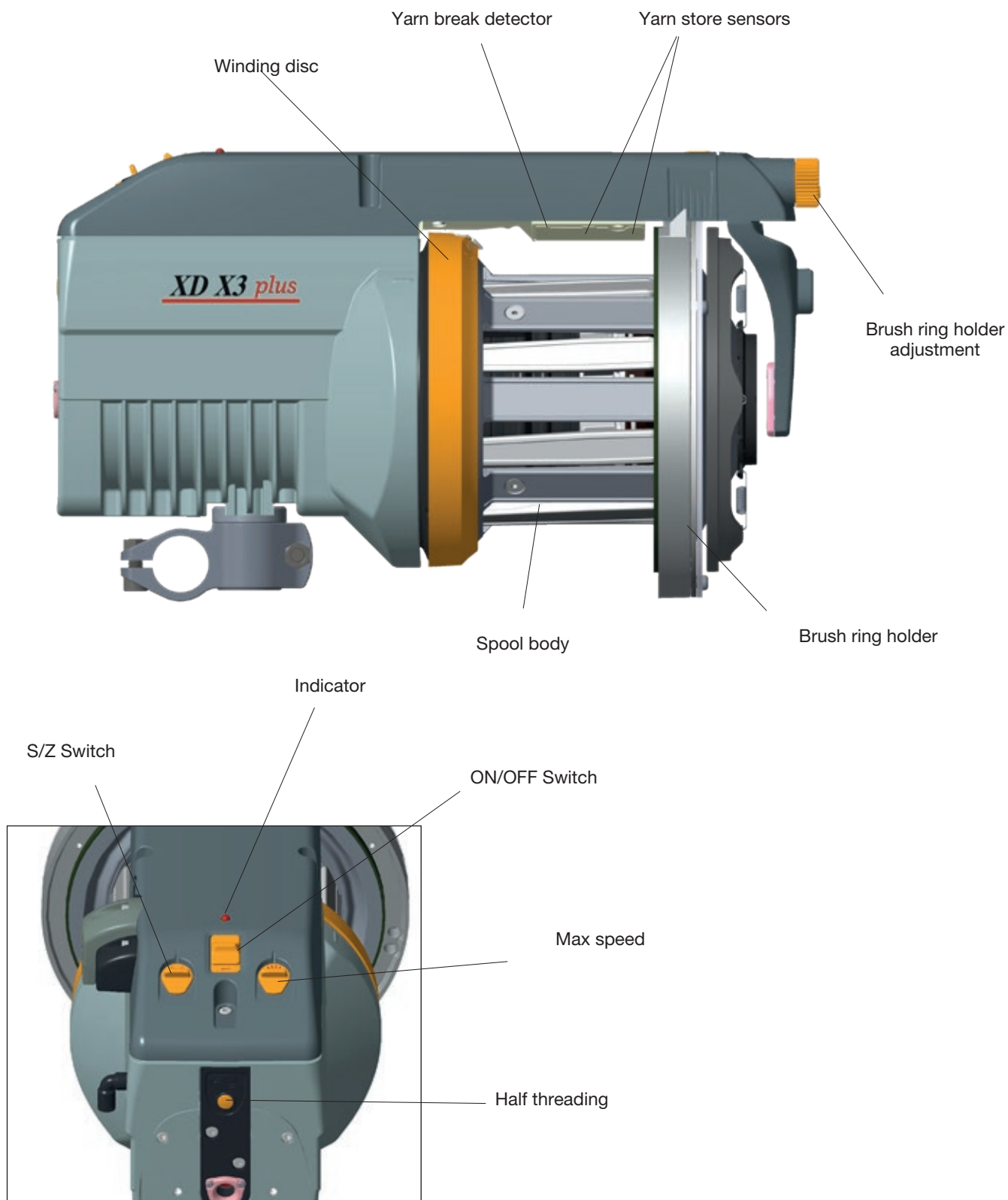

HD X3

NOTE

Do not expose the brush ring holder or the winding disc to external forces as this may cause damage / deformation.
 Do not, for instance, carry the feeder by holding it in the brush ring holder.
 Store the feeder resting on the back or top cover to avoid damaging / deforming mentioned parts.

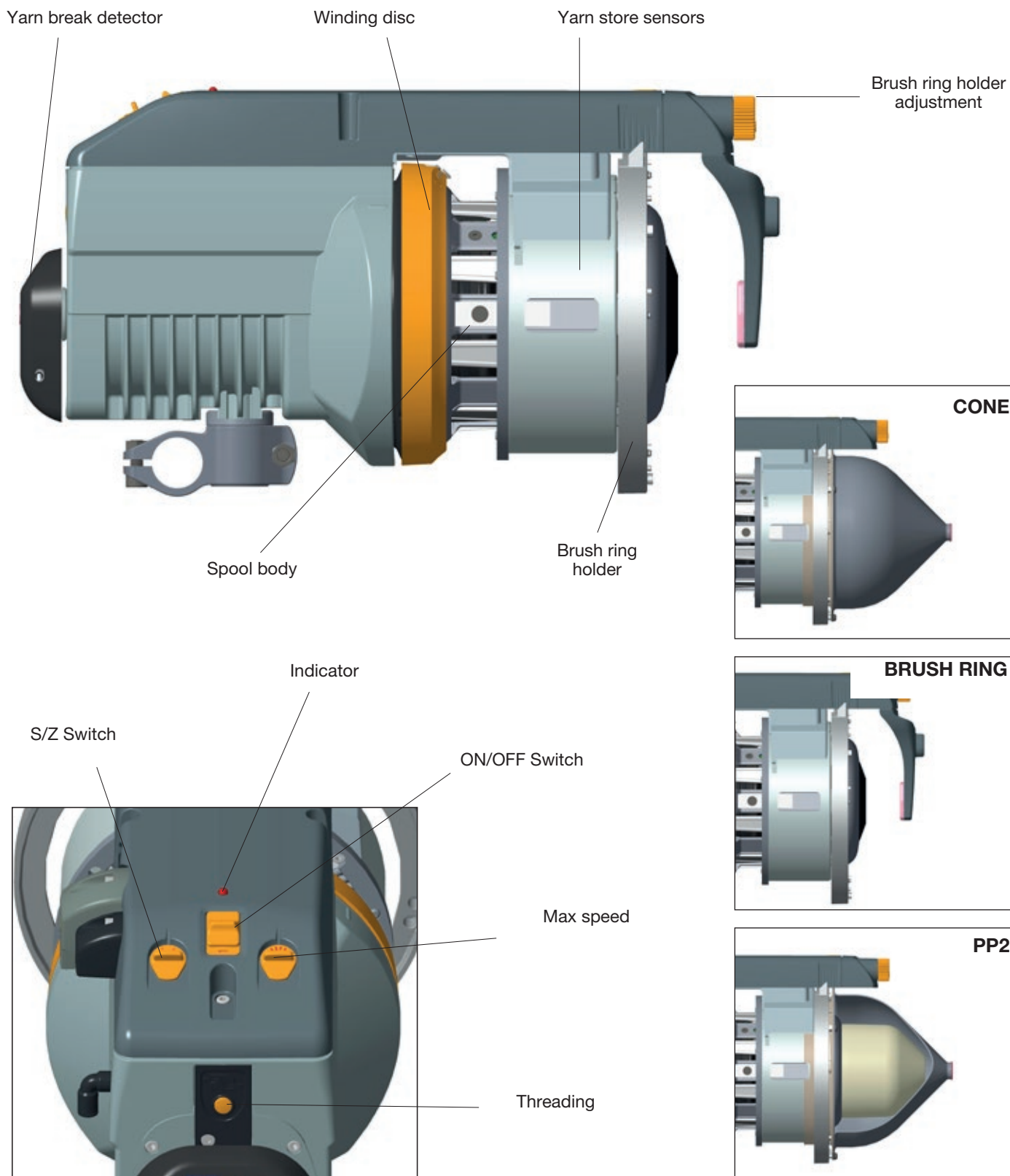

Switch off the feeder.

On feeders with S-flex, the S-flex must be detached for making the S/Z adjustment.
See page 31-32 (Flex-brake mounting).



Grip the winding disc and, whilst pressing the orange button on the front of the spool body, rotate the disc until the button is felt to locate. Aligning the mark on the winding disc with the line on the motor house gives the zero separation position.

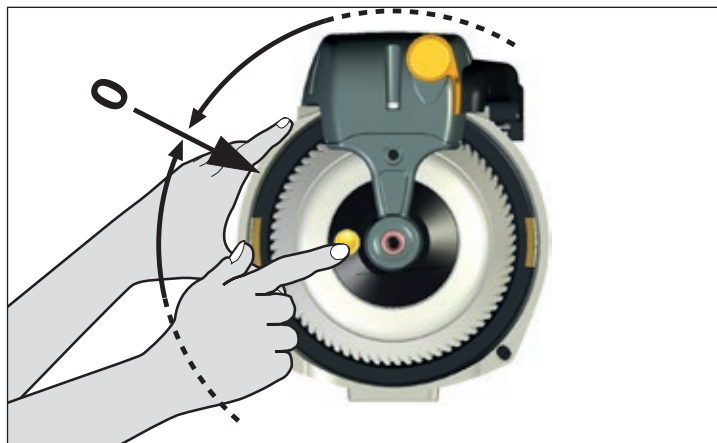

To adjust, press in the button and revolve the winding disc in the appropriate direction. The separation increases from 0 to 4 mm the more the disc is rotated.

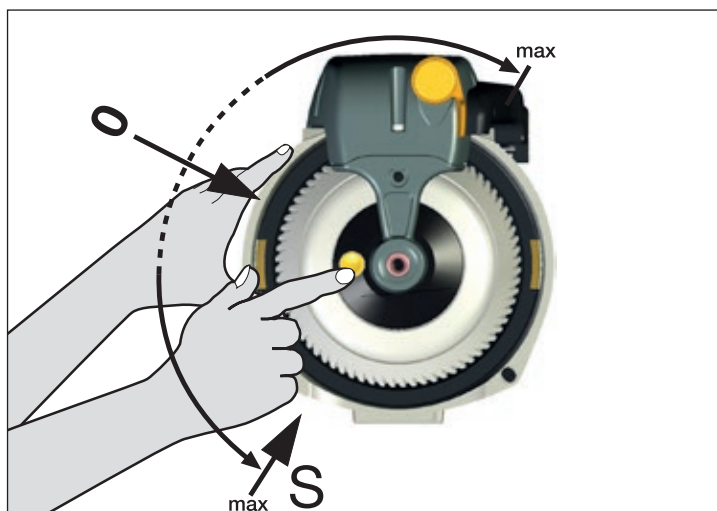

NOTE

Before starting the automatic sensors calibration, check the following:

The separation must be distinct, but not excessive.

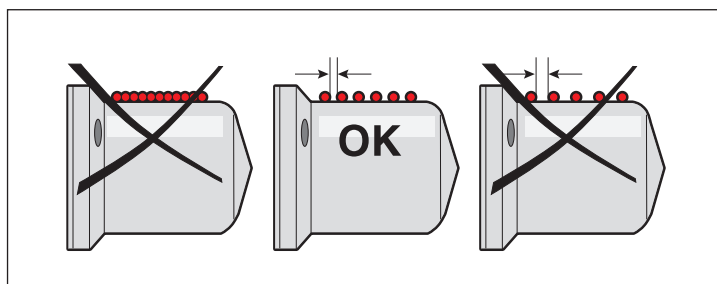

Set the direction of rotation with the switch. (The feeder is deactivated in the standby position (0))

NOTE

On feeders with brush, choose the correct type of brush (S, Z or Straight) depending on the direction of the rotation. See page: 32

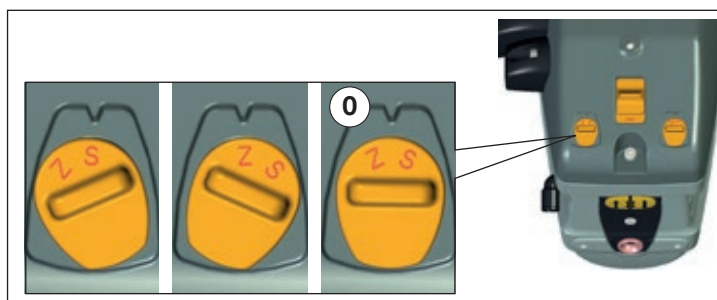

Luna X3, Chrono X3, XDX3

FULL THREADING, AUTOMATIC SLIDE SHIFT

- Restart the feeder to automatically position the winding disc (empty spool body)
- Insert the yarn into the eyelet and press both buttons, whilst lightly holding the yarn.

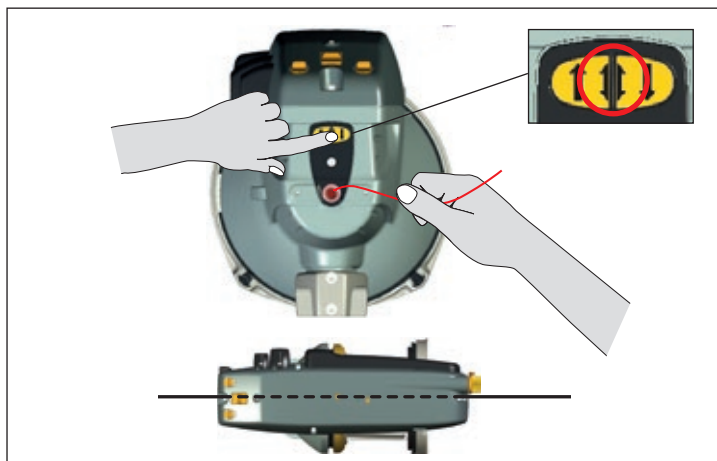

FULL THREADING, MANUAL SLIDE SHIFT

- Restart the feeder to automatically position the winding disc (empty spool body)
- Open the brush holder, see page 30.
- Insert the yarn into the eyelet and press both the buttons, whilst lightly holding the yarn.

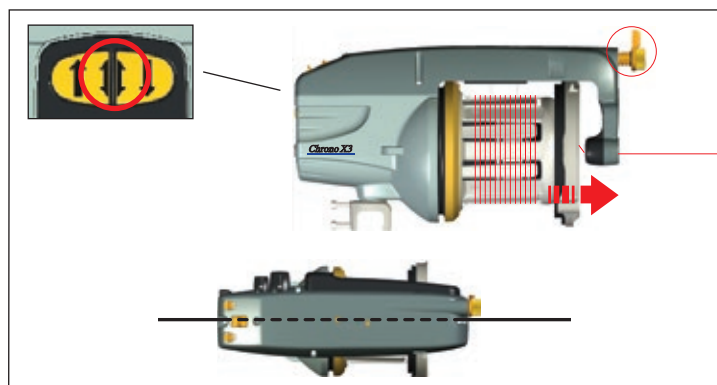

HALF THREADING, BACK

Insert the yarn into the eyelet and press the right button, whilst lightly holding the yarn.

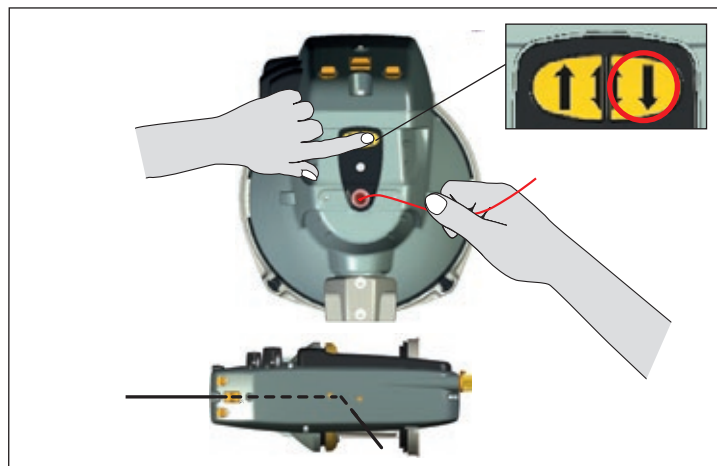

HALF THREADING, FRONT

Insert the yarn into the eyelet and press the left button, whilst lightly holding the yarn.

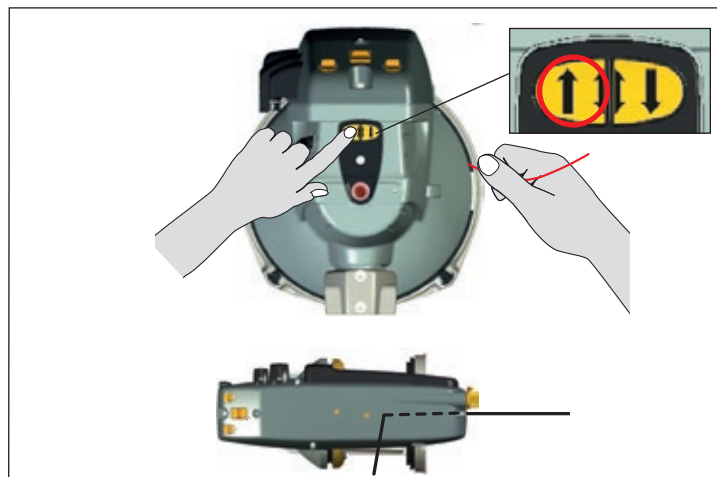

Luna X3, Chrono X3, XD X3, XD X3 Plus

WITHOUT CAT

- Switch off the feeder.
- Align the winding disc eyelet (1).
- Open the brush holder (see page 30,32).
- Thread the needle all the way through the feeder and output eyelet.
- Pull the yarn through.
- Restart the feeder.

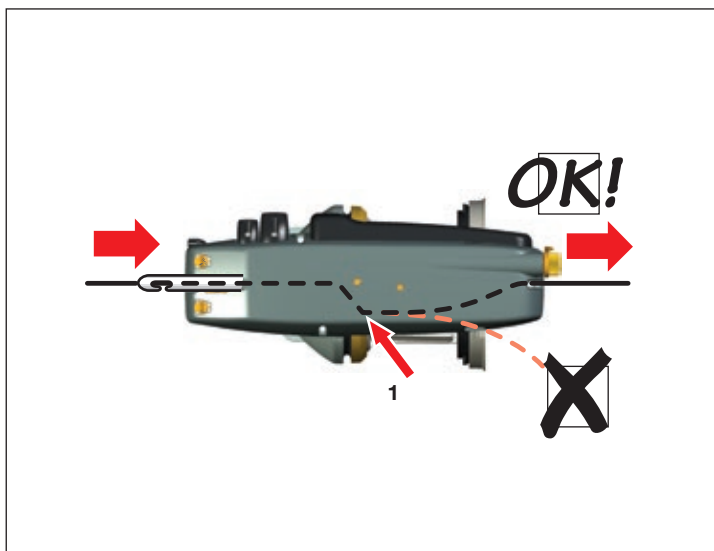

WITH CAT

- Switch off the feeder.
- Align the winding disc eyelet.
- Thread the needle through the feeder and balloon control brush.
- Start the feeder and fill the yarn store.
- Insert the threading needle into the CAT (2) as far as possible.
- Pulling the yarn (3) will cause it to wrap around the threading needle.
- When the threading needle is pulled out (4) the yarn will follow.

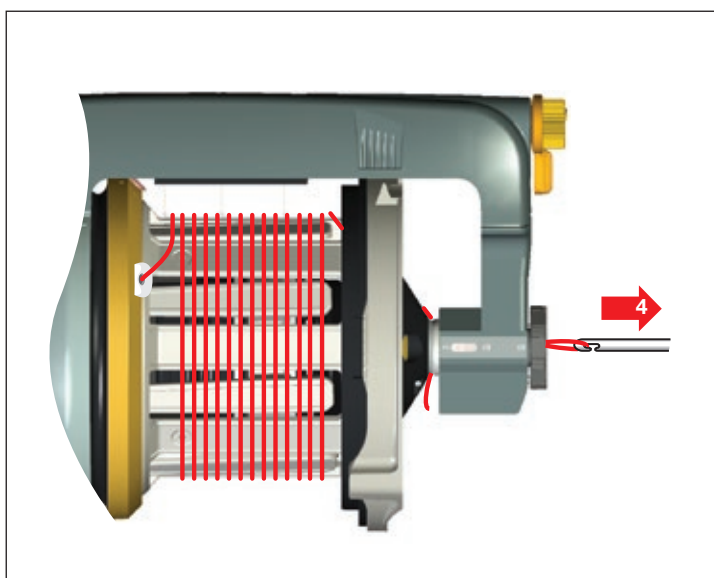
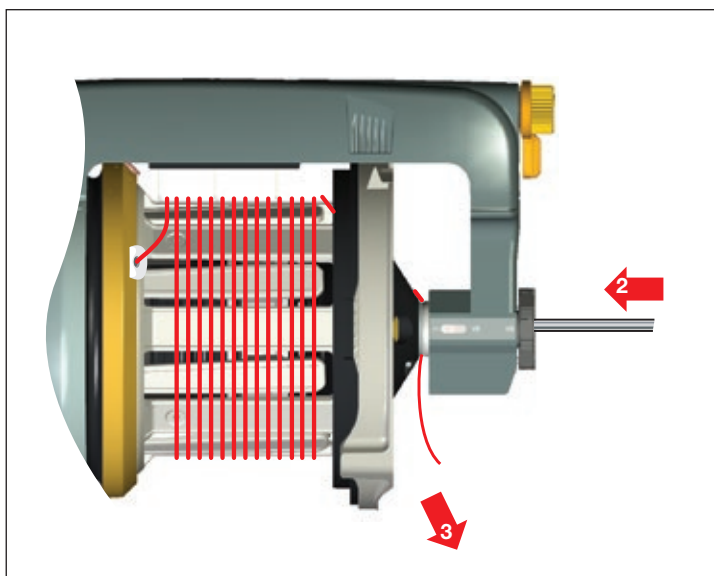

WARNING

When using a threading needle, care must be taken to avoid damaging the Flex brake. Ensure that the flex holder is in the forward position before threading.

HD X3

Switch on the feeder.
The winding disc will automatically position itself (empty spool body).

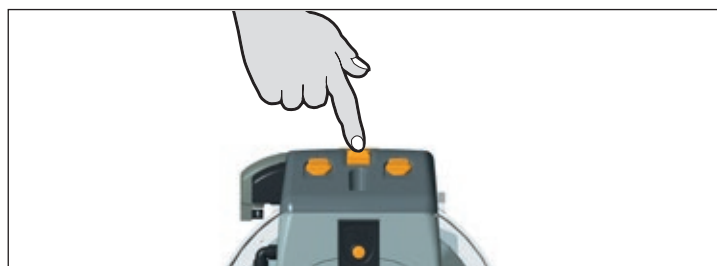

HALF THREADING

Insert the yarn into the eyelet and press the button, whilst lightly holding the yarn.

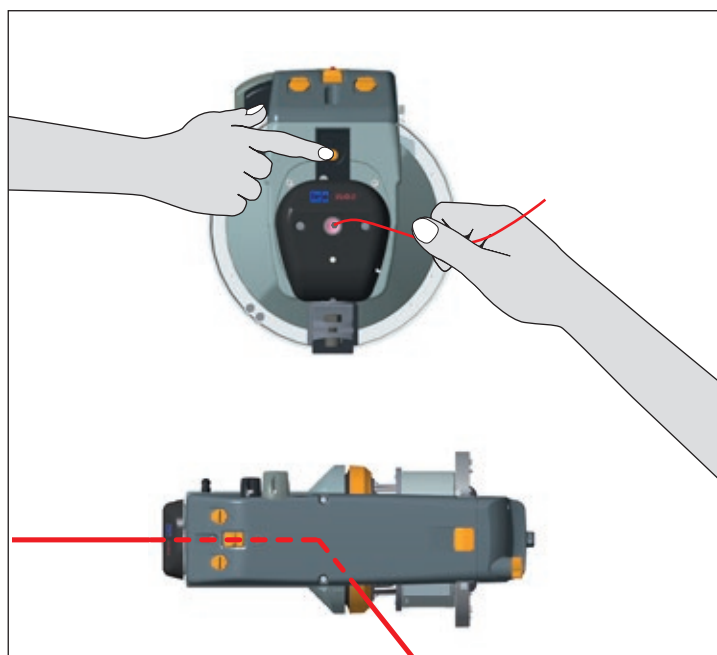

MANUAL THREADING

1. Align the winding disc eyelet (1).
2. Open the brush holder (see page 32).
3. Thread the needle all the way through the feeder and output eyelet.
4. Pull the yarn through.
5. Restart the feeder.

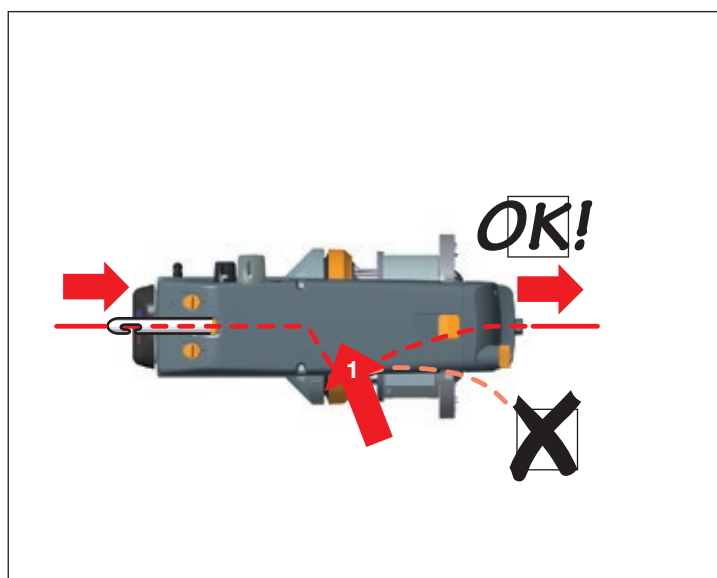

 **WARNING**

When using a threading needle, care must be taken to avoid damaging the Flex brake. Ensure that the flex holder is in the forward position before threading.

1. Ensure that the spoolbody sensor part is in the correct position

Optical sensors

2. Certain yarn types may stick to, or leave deposits on, the sensor mirror. In such cases the clearance between the yarn and the mirror can be increased.

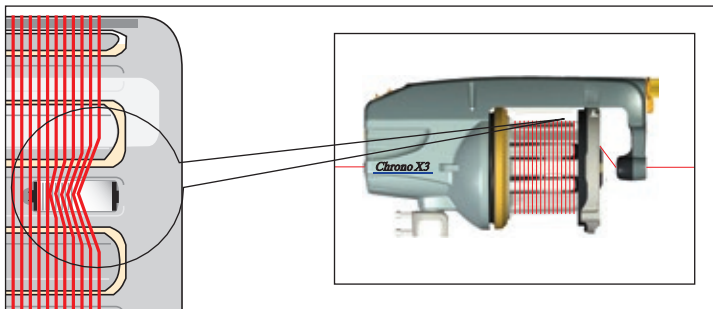

3. Adjust the clearance by rotating the mirror 180 degrees.

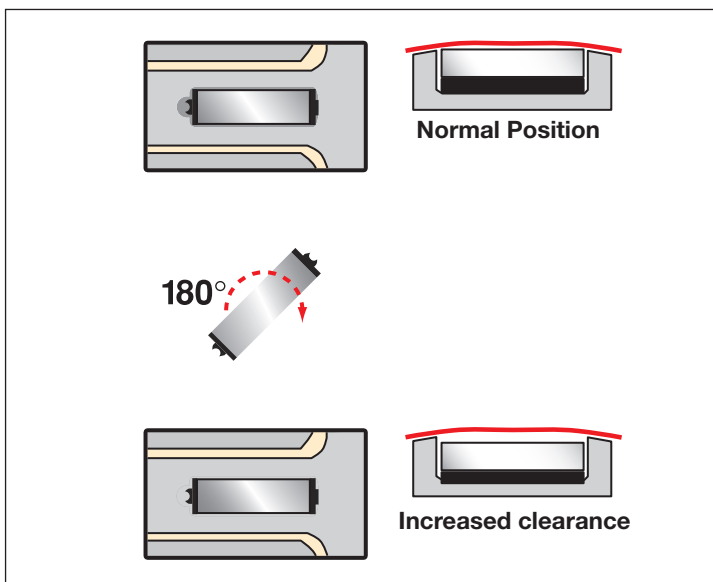

Mech. sensor

2. Certain yarns may cause excessive vibration of the sensors. This can be remedied by increasing the damper pressure.

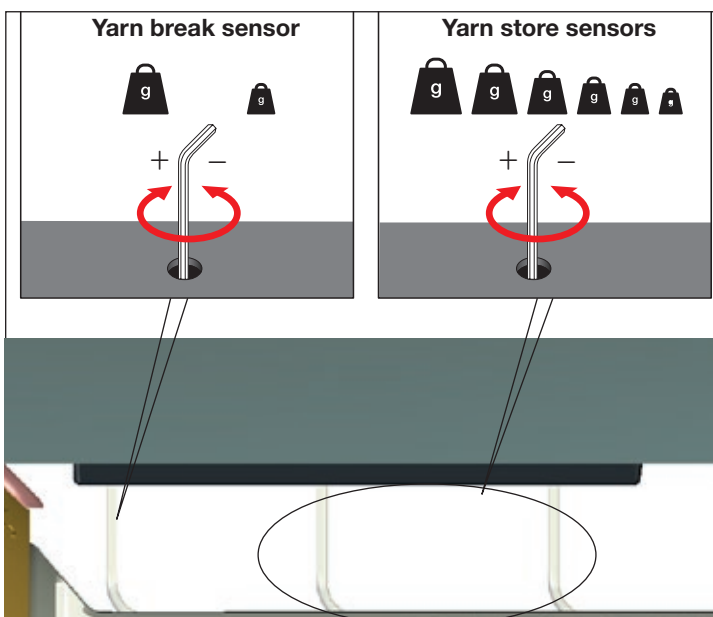

HD X3

The mechanical sensors are placed on the fixed part of the spool body.

The sensor (1) controls MAX reserve level, and the sensor (2) controls MIN reserve level.

The force needed to press down the sensors is controlled by a spring, and it is adjustable with screw (3). Turn the screw (3) anti-clockwise to increase the sensor strength, turn it clockwise to reduce it.

AUTOMATIC CALIBRATION OF THE SENSORS

NOTE

Before starting the automatic sensors calibration, check the following:

- Remove all yarn from the feeder
 - The spool body must be in correct position.
 - The sensors must be free to correctly move up and down.
 - The sensors ring must be correctly fixed.
1. Switch OFF the feeder.
 2. Disable the TFE9 by moving the switch (4) upwards. The LED of TFE9 must be steady-ON in red color.(5)
 3. Switch ON the feeder and let it turn without weft for at least 50 revolutions, until the winding disk stops. (feeder red light steady ON).
 4. Switch OFF the feeder, and enable the TFE9 by moving the switch down
 5. Thread the yarn through the feeder (see page 25)
 6. Switch ON the feeder and load a new weft reserve.

LED (5)

When disabled, the LED (5) is steady RED ON.

When enabled, the LED (4) is GREEN only when the yarn is creating signal, otherwise it is OFF.

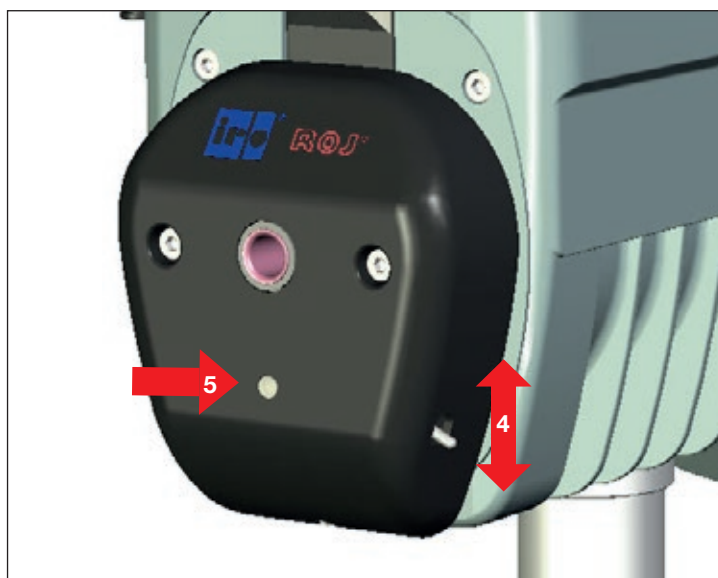
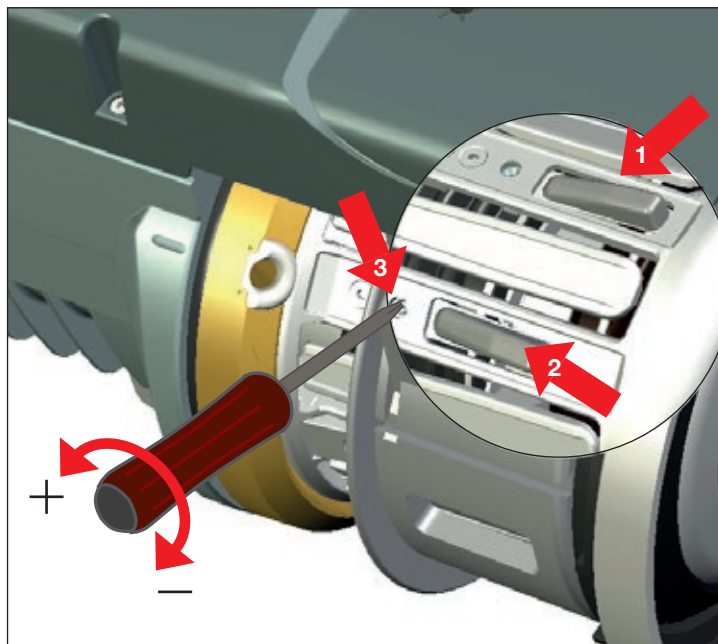

TENSION SETTINGS

BRUSH

When using a brush it is possible to use the whole setting area of the brush holder ring.

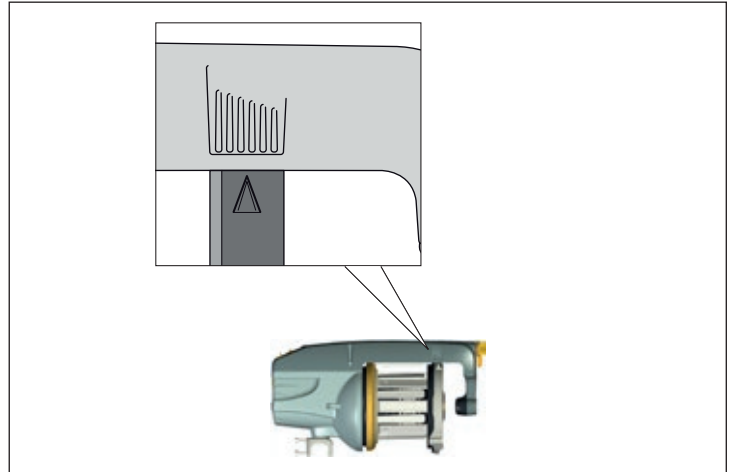

FLEX

When using a flex it is important to keep the settings in the center of the setting area, to ensure proper tension and longer life time of the flex. Avoid to set the brush ring in the outer areas.

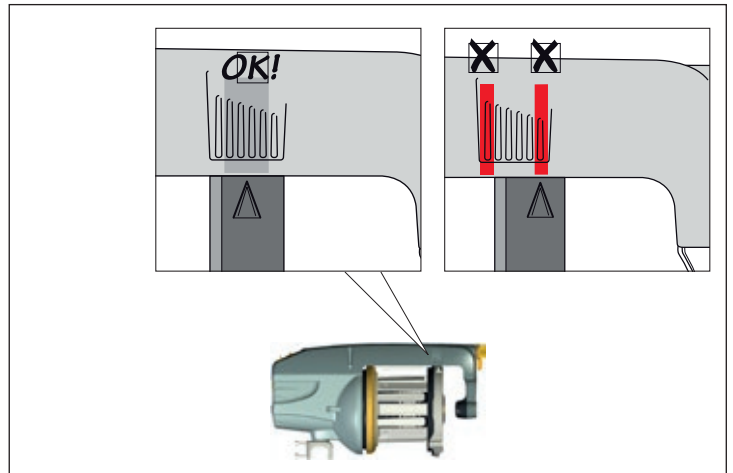

BALLOON CONTROL

Balloon control adjustment.

NOTE

Excessive brush tension will cause abnormal wear.

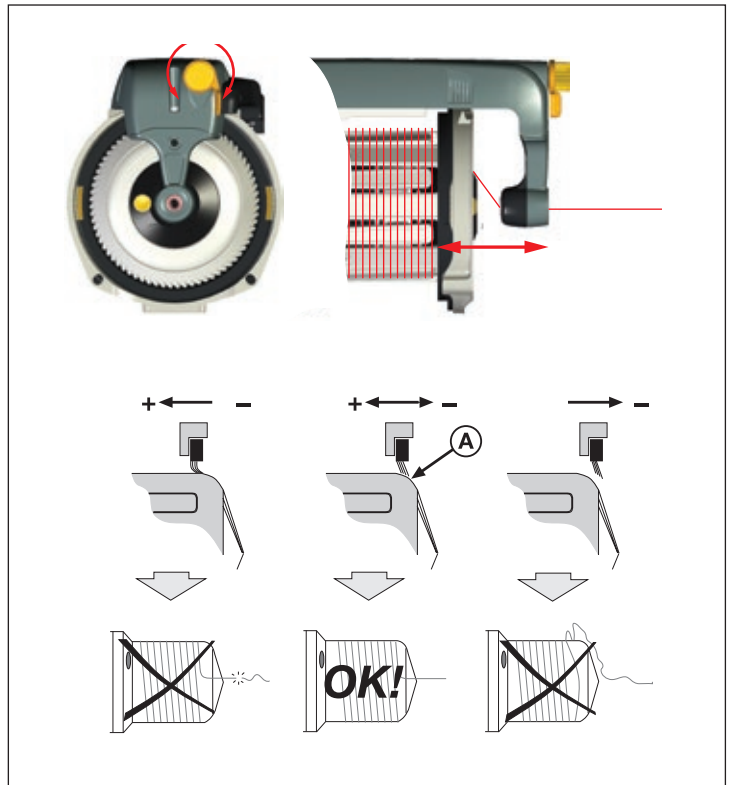

XD X3, XD X3 Plus, HD X3

Ramps are used when weaving with none elastic yarns that become too tightly wound around the spool body.

One, two or three ramps can be mounted.

Start with mounting one and if needed, mount additionally.

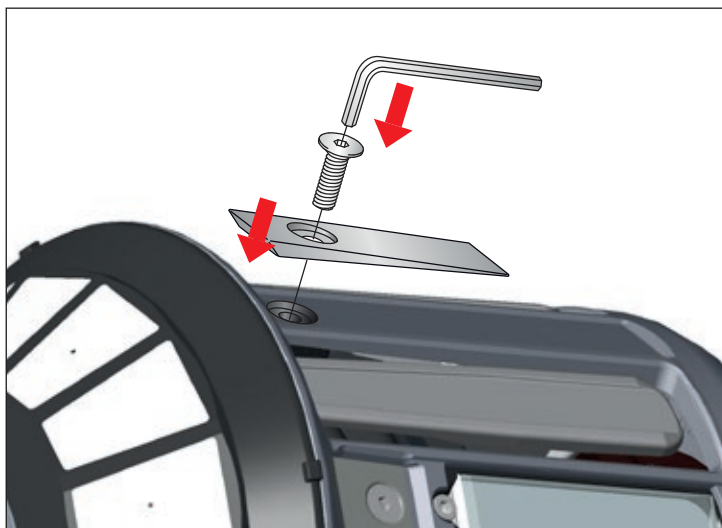
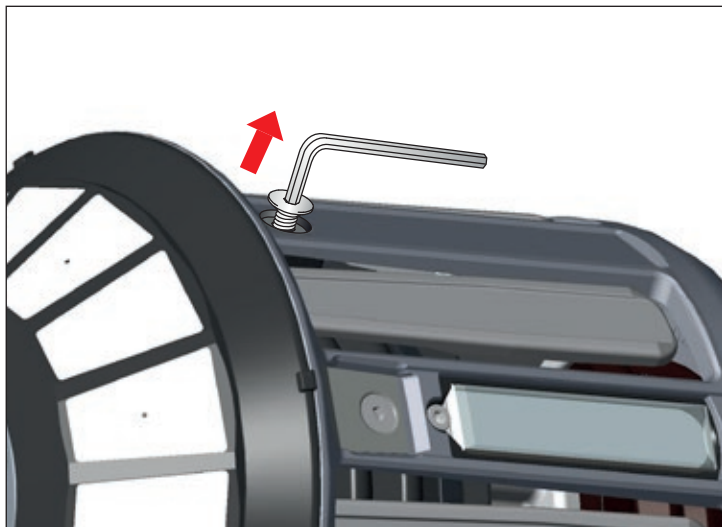

BRUSH RING ALTERNATIVE

Z for Z-rotation

S for S-rotation

Straight for Z and S rotation

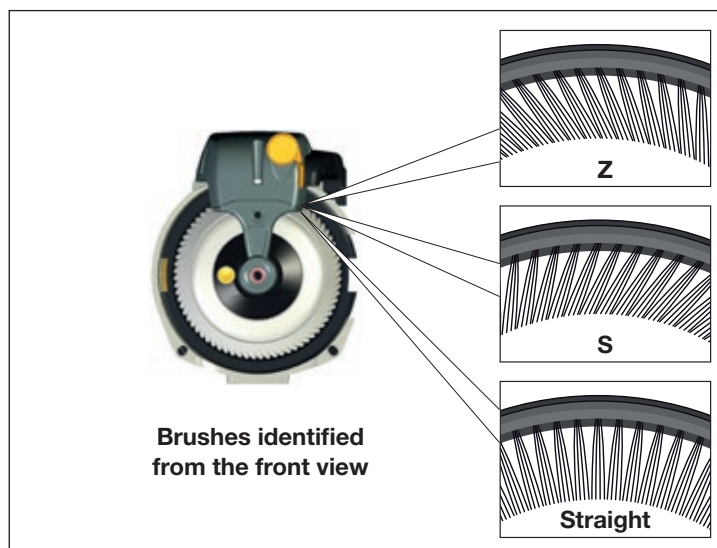

BRUSH MOUNTING

Rotating the slide shift lever (1) will detach the brush holder (2) from the spool body.

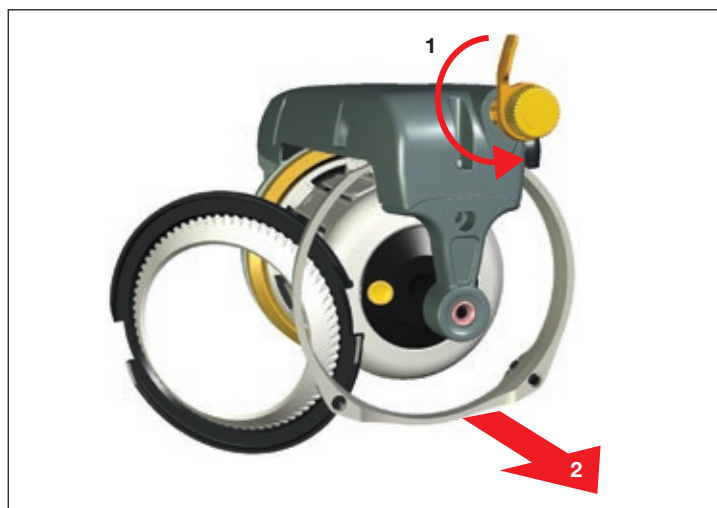

Ensure that the brush ring is correctly positioned (3) when attaching.



MOUNTING

Rotating the slide shift lever (1) will detach the brake (2) from the spool body.

NOTE

It is important to use a brake suited for the specific application to prevent reduced life time of the brake.

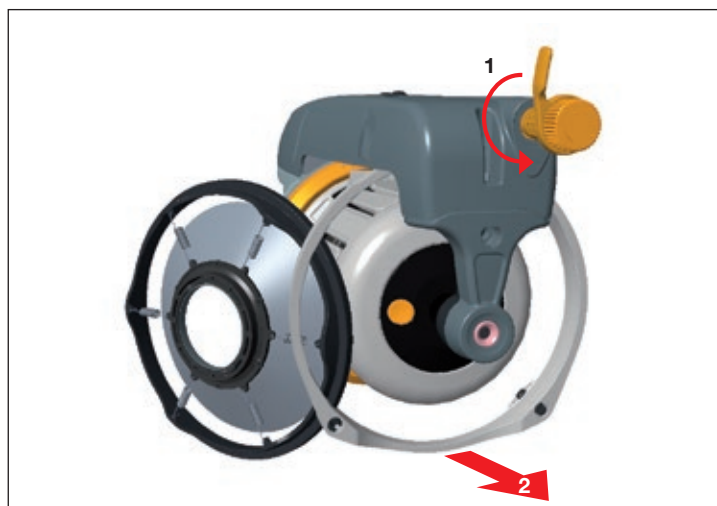
NOSE OUTPUT: FLEX BRAKE

Attach nose output depending on the mounted type of Flex brake to ensure function.

NOTE

The performance of a tensioner can be affected by various factors connected to the specific yarns being used. In case of uncertainty it is recommended to carry out a weft insertion test.

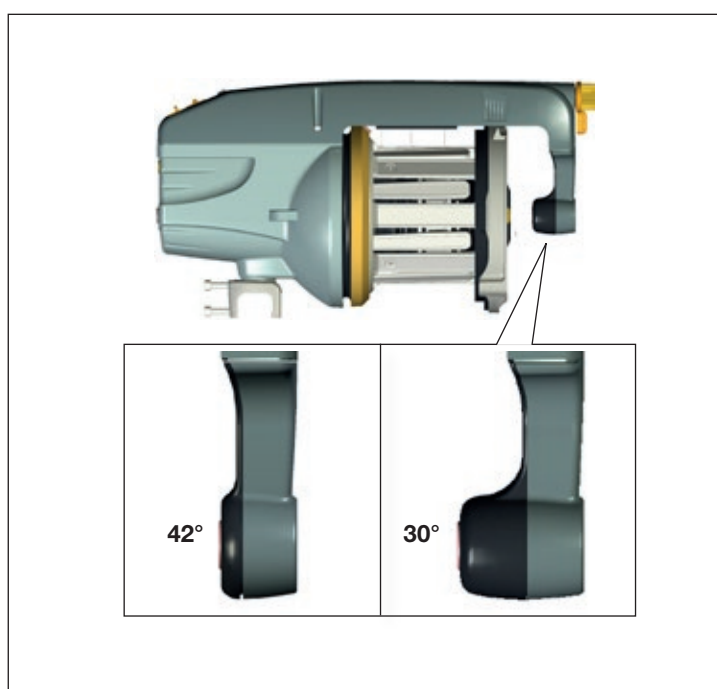
NOSE OUTPUT: LAMELLA CAGE

Using a Lamella cage requires a 42° nose output.

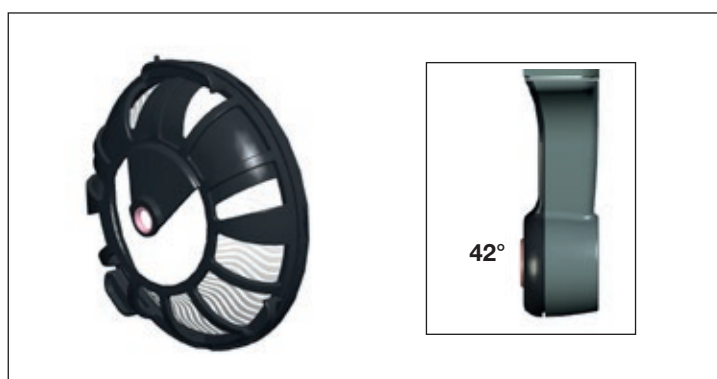

BRUSH RING ALTERNATIVE

Z for Z-rotation

S for S-rotation

Straight for Z and S rotation

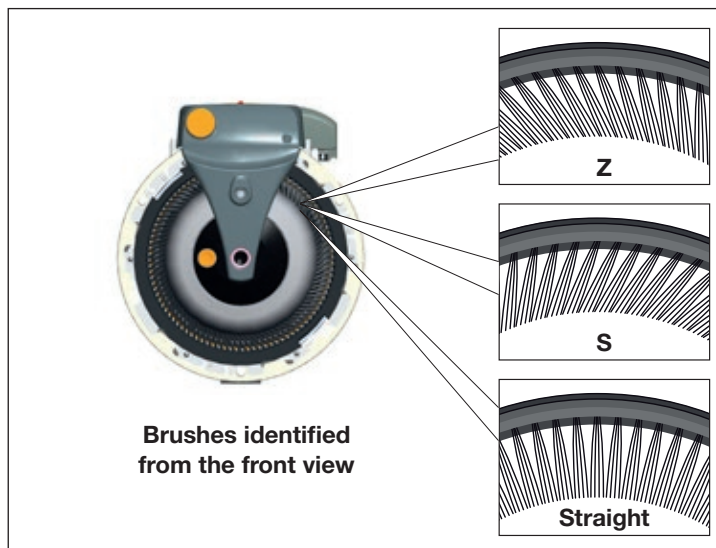

MOUNTING

Rotating the slide shift lever (1) will detach the brake from the spool body.



Ensure that the brush ring is correctly positioned (2) when attaching.



NOTE

It is important to use a brake suited for the specific application to prevent reduced life time of the brake.

NOSE OUTPUT: FLEX BRAKE

Attach nose output depending on the mounted type of Flex brake to ensure function.

NOTE

The performance of a tensioner can be affected by various factors connected to the specific yarns being used. In case of uncertainty it is recommended to carry out a weft insertion test.



THREADING THE TEC

- Open the cover (1)
- Insert a threading needle (2)
- Pull on the yarn (3). The yarn will wrap itself around the needle
- Pull out the needle (4)
- Close the cover (5)

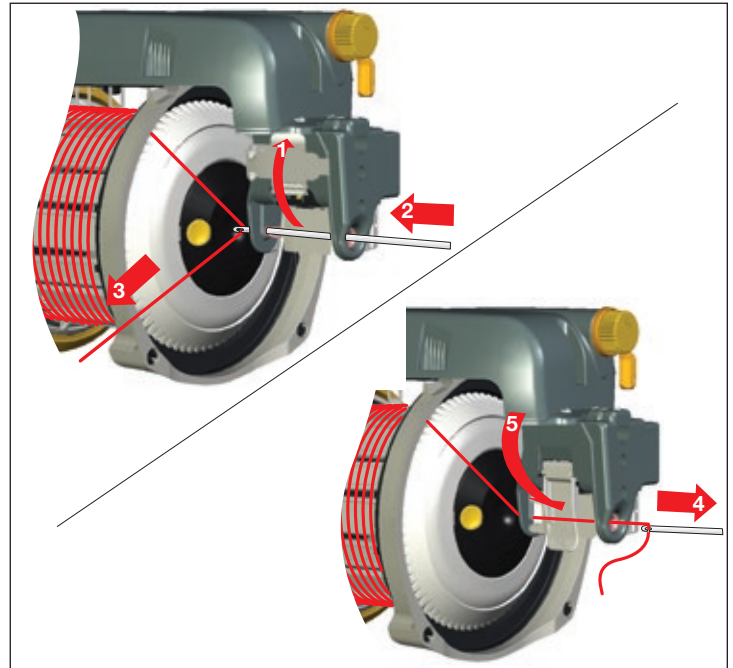
Position A

Using the TEC together with a 30° FlexBrake.

Position B

Using the TEC together with a 42° Flexbrake or Lamella cage.

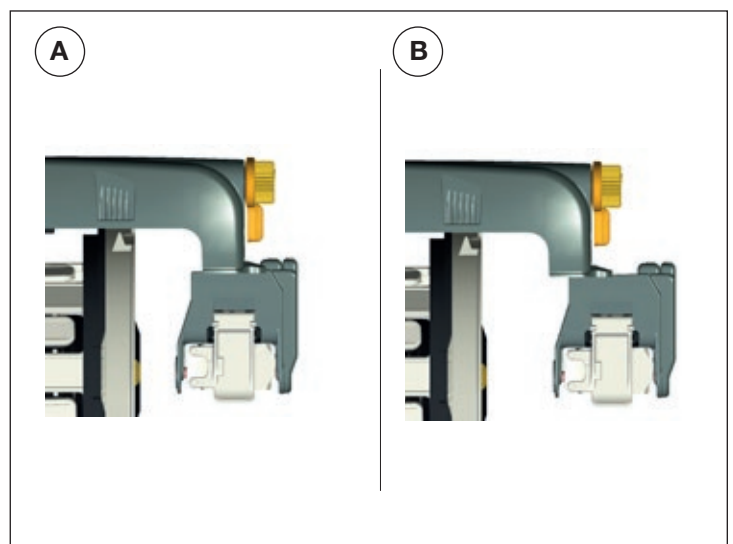
CHANGING THE TENSION STRIP

- Open the cover (1)
- Remove the cap (6)
- Tilt the strip to remove (7)
- Tilt the new strip forwards to insert
- Close the cover (5)

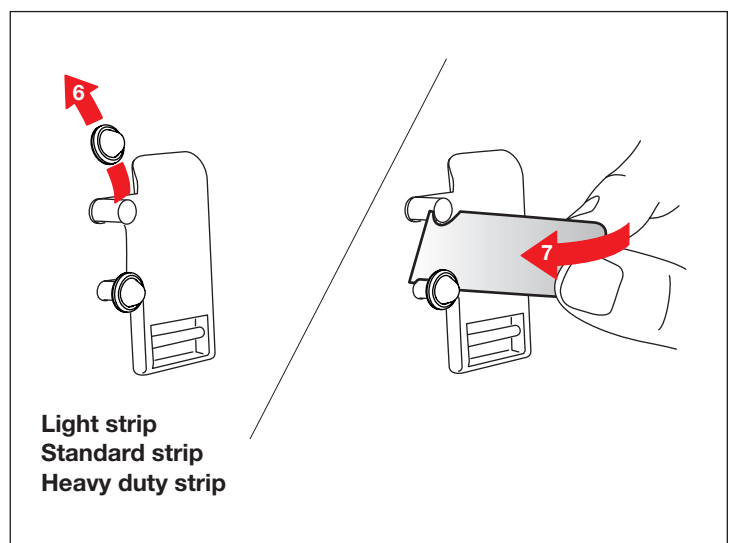

INPUT TENSION

Control input yarn tension to the CAT.

NOTE

The brush ring should only be used for balloon control.

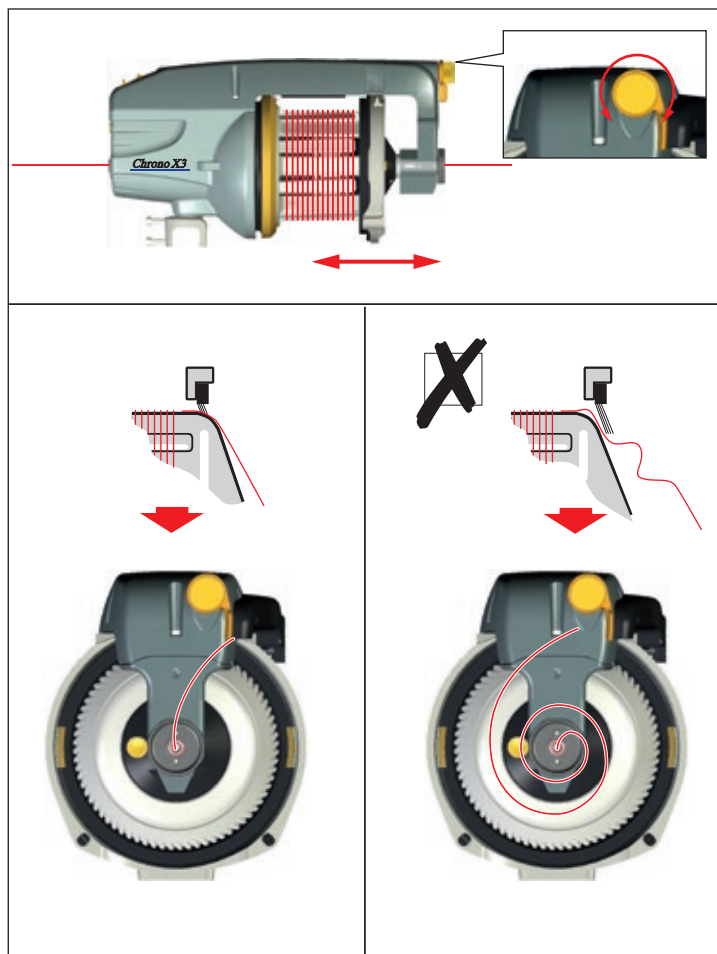

OUTPUT TENSION

Adjustment of the output tension.

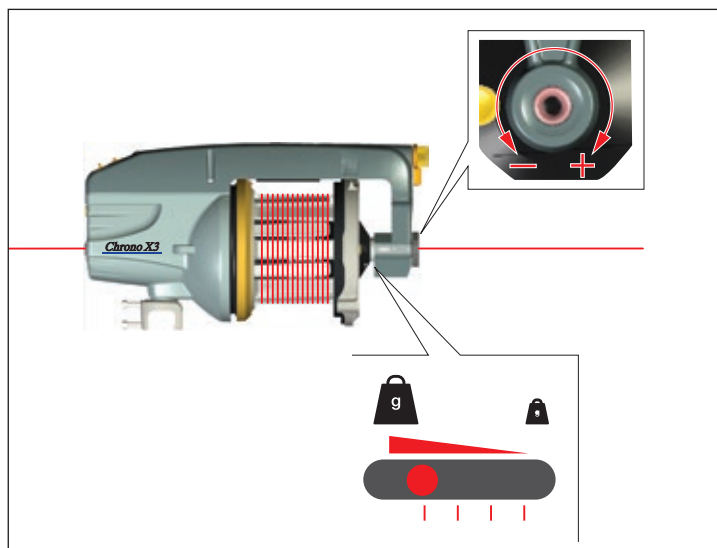

Balloon control adjustment.

NOTE

Excessive brush tension will cause abnormal wear.

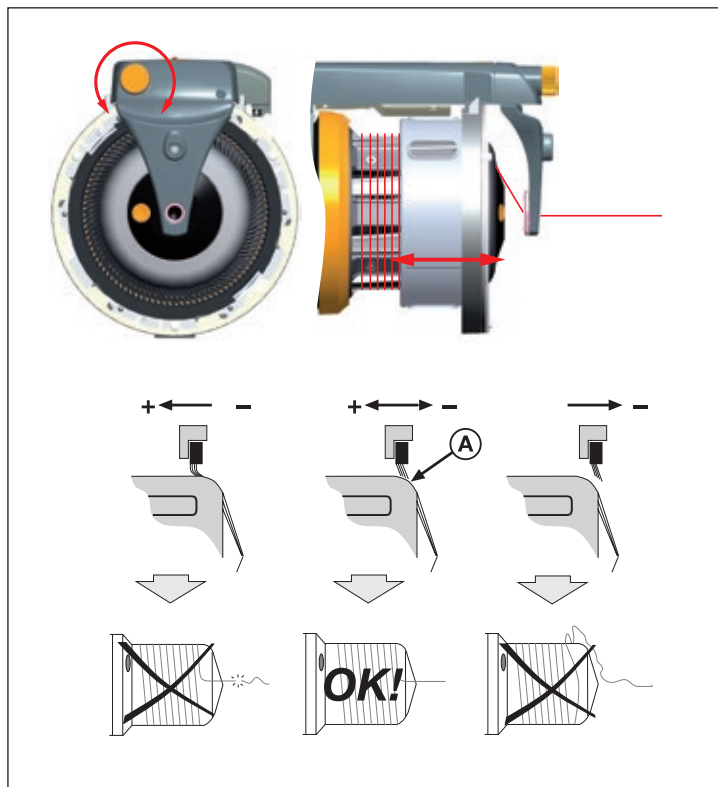

NOSE POSITION

Mounting position of the nose: 30° or 42°

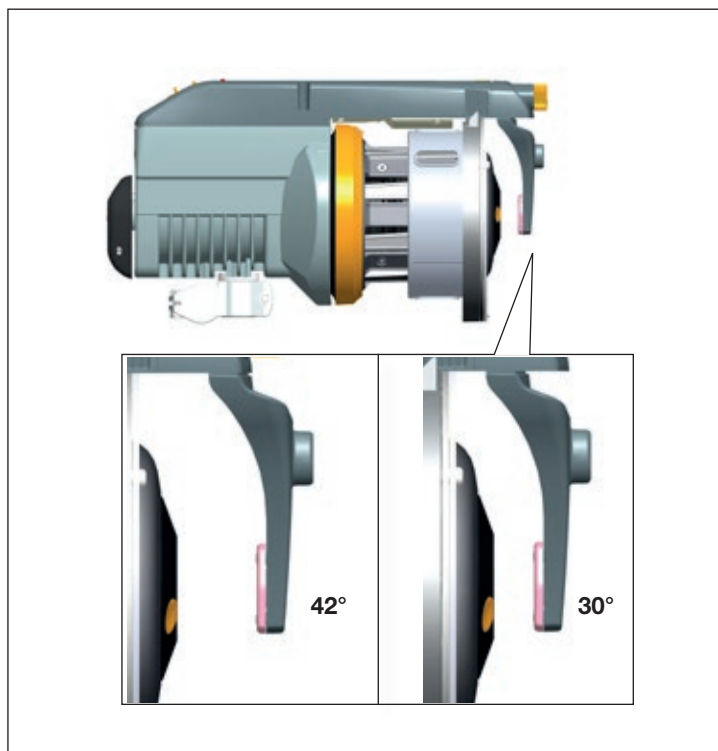

Suitable for heavy yarns which create large balloons.
Suggested for polypropylene flat tape on projectile looms.

NOTE

There is no braking function on the yarn when the funnel is installed since it is used only to control the balloon effect during the yarn taking-off.

Remove the brush holder by pressing the button (1) on the top.

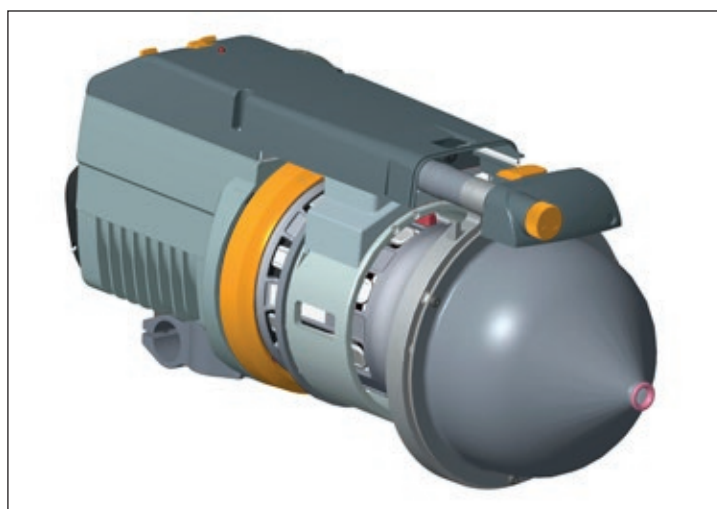
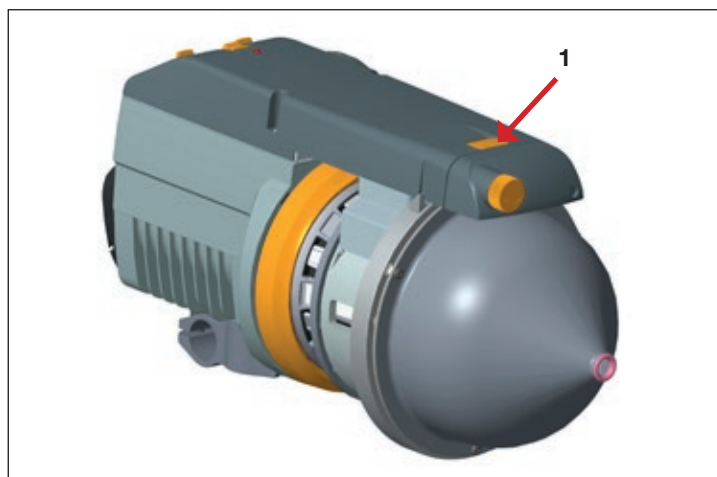

FUNNEL SCREWS

The cone is kept in place by the three funnel screws (2).
The funnel screws are thread locked (loctite) and tightened to recommended torque (3Nm).

NOTE

If the funnel screws are unscrewed or loose, be sure to add new thread locking (loctite) and tighten screws to recommended torque (3Nm).

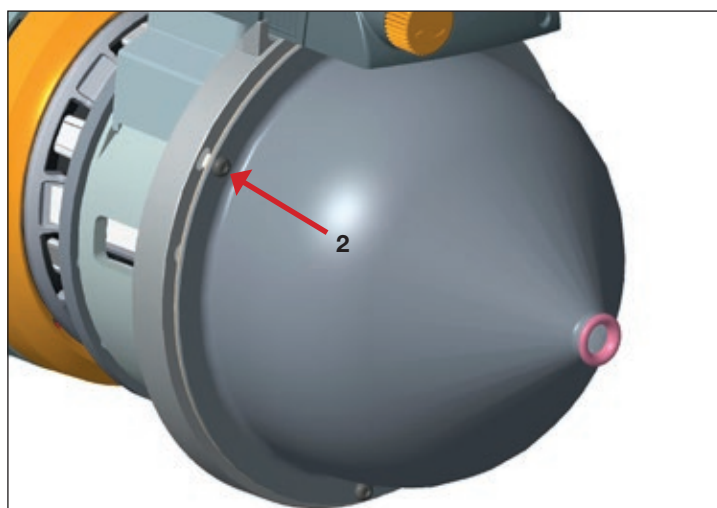

Chrono X3, XD X3, XD X3 Plus, HD X3

After disassembling, it is necessary to install the spool-body part by part to avoid damaging the parts. Secure the bellow properly with plastic straps (1).



Be sure that the carrier pin fits into the keygroove in the motor shaft (2).

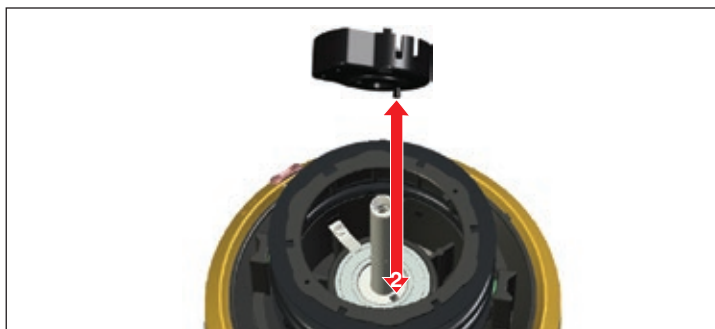

Insert the two screws (four screws in HD X3) for the rubber bellows (3) and be sure they are properly tightened with the correct key. (Torx T10)

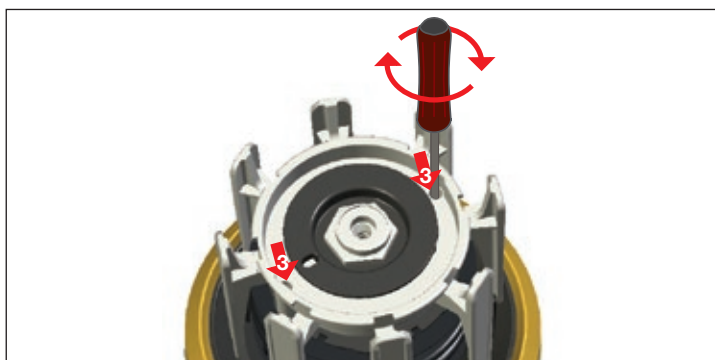

Turn the winding disc (4) when holding the centre nut (5) to get the balance weight in position. When correct, the disc can easily be moved 180° only.

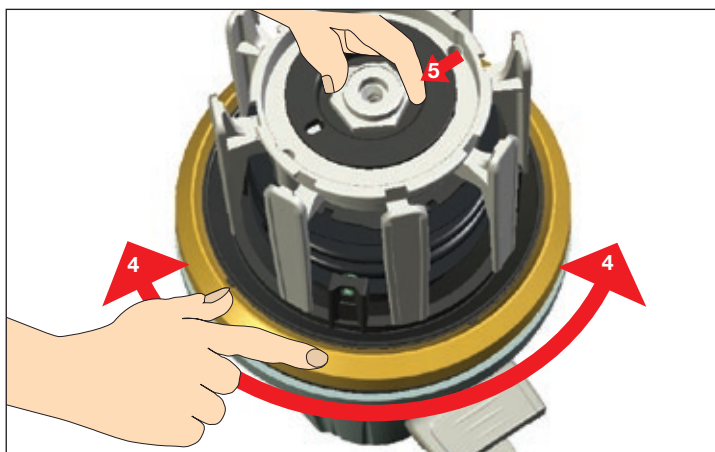

Install the centre screw, outer rubber bellows, spoolbody and cover. Set the yarn separation to a suitable position to be sure it is correctly assembled.



LUBRICATION

The unit requires no extra lubrication.



CONNECTIONS



WARNING

Always turn off the main switch or isolate the power supply and disconnect the air supply before connecting or disconnecting the feeder, the control board or any of the circuit boards.

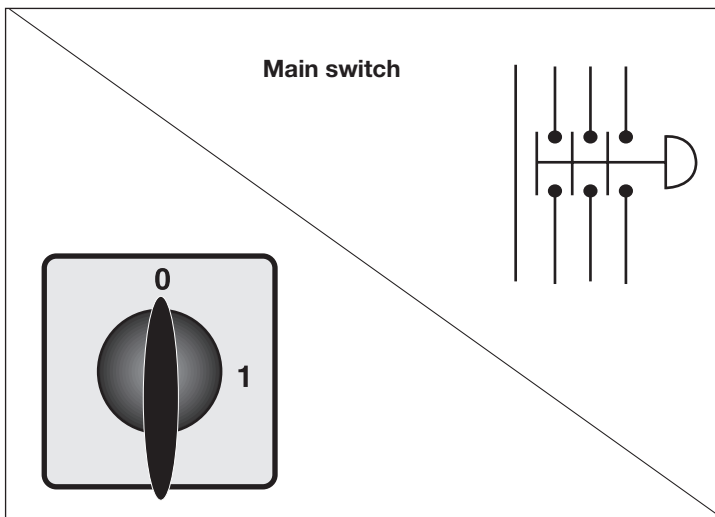

NOTE

The connector cover must be assembled before re-start.

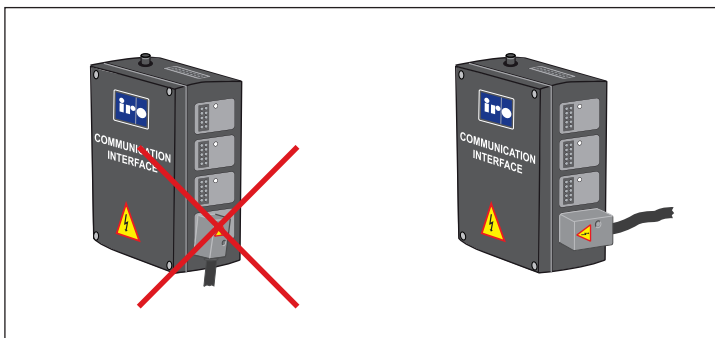

IRO/ ROJ TOOL KIT

It is recommended to use an IRO tool kit, with specialised tools, to ensure easy and correct disassembly/assembly of IRO feeders during maintenance work. Please contact your local IRO service station for further information.

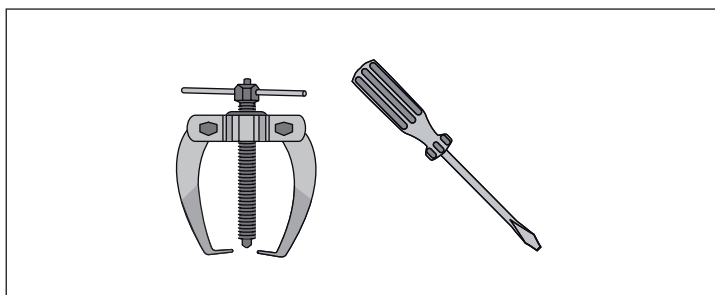

CLEANING

It is recommended to carry out a periodical cleaning of any lint or dust accumulation on the feeder and the control box.

NOTE

Avoid the use of compressed air when cleaning the feeder.

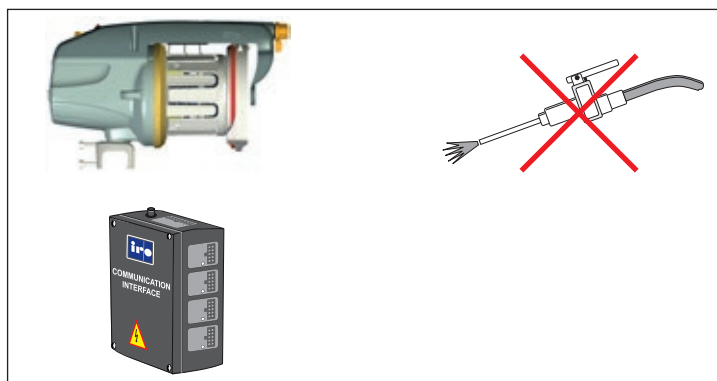

XD X3 Plus, HD X3

Cleaning the spool body

Remove the brush holder by pressing the button (1) on the top. Clean the spool body with compressed air.

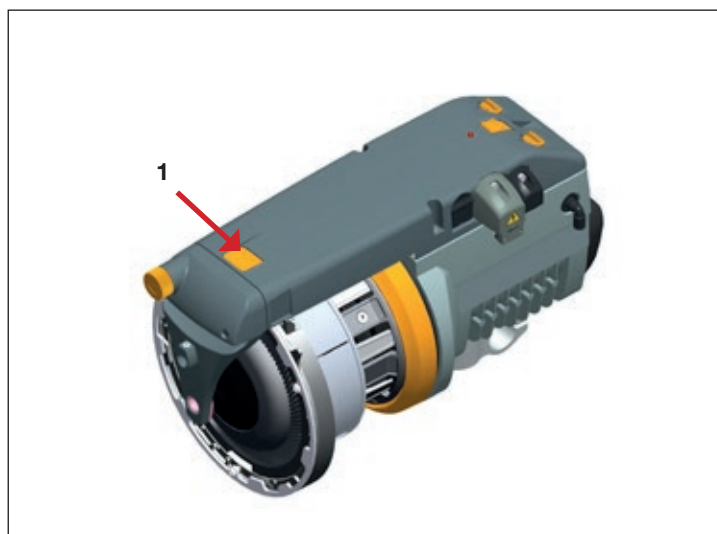

CAUTION

If the brushholder is completely removed it is important to clean the piston and its seat (2) with compressed air to prevent dust to enter and disturb the normal piston movement.



Luna X3, Chrono X3, XD X3

Fault	Check in the following order	
	Optical sensor	Mechanical sensor
Feeder will not start	1 - 2 - 3 - 4 - 6 - 7 - 8 - 24 - 25 - 26	1 - 2 - 3 - 5 - 6 - 7 - 8 - 24 - 25 - 26
Feeder will not stop	2 - 4 - 24 - 25	9 - 13 - 5 - 15 - 24 - 25
Low or empty yarn store	4 - 3 - 13 - 9 - 8 - 21 - 14 - 24 - 25 - 27 - 26	17 - 3 - 5 - 16 - 13 - 9 - 8 - 21 - 24 - 25 - 27 - 26
Input yarn breaks frequently	22 - 10 - 13	22 - 10 - 18 - 14
Output yarn breaks frequently	11 - 20 - 12 - 19 - 23	11 - 20 - 12 - 19 - 23
Fuses blow repeatedly	25 - 28	25 - 28
Feeder warning light flashes slowly	4	9 - 13
Feeder warning light flashes rapidly	3 - 9 - 8 - 27	3 - 9 - 8 - 27
Feeder warning light continuously on	29	29

No	Possible causes	Remedies	See page
1.	Incorrect S/Z switch position	Set the S/Z switch in appropriate position	22
2.	Incorrect spoolbody position	Ensure the sensor unit is positioned upwards	26
3.	Winding disc jammed	Free and clean the winding disc	39
4.	Contaminated sensor or mirror	Clean the sensor and mirror using a mild cleaning agent	26
5.	Sensor arms jammed	Free the arms and clean the sensing unit	39
6.	Faulty cable connections	Check and rectify	6-9
7.	Fuses blown	Replace the relevant fuse	8-9
8.	Mains supply / primary voltage fault	Check the mains supply and connections	6-9
9.	Insufficient input tension	Increase the input tension	-
10.	Excessive input tension	Reduce the input tension	-
11.	Insufficient balloon control	Increase the balloon control	28,34
12.	Excessive output tension	Reduce the output tension	28,34
13.	Excessive yarn separation	Reduce the yarn separation	22
14.	Incorrect jumper J1 setting	Reposition jumper	16
15.	Excessive pressure on max sensor arm	Reduce the spring pressure	26
16.	Max sensor bouncing	Increase the spring pressure	26
17.	Insufficient max speed setting	Increase the max speed setting	18
18.	Excessive max speed setting	Reduce the max speed setting	18
19.	Insufficient yarn store	See "low or empty yarn store" under "fault"	-
20.	Damaged balloon control	Repair/replace all defective parts	3
21.	Stop signal fault between control box and weaving M/C	Check all connections/cable	8-9
22.	Misalignment between the bobbin and the feeder	Realign the bobbin/feeder	-
23.	Misalignment between the feeder and the machine	Realign the feeder/machine	-
24.	Defect yarn store sensor unit	Replace the relevant sensor unit	19
25.	Defective motor circuit board	Replace the relevant circuit board	7
26.	Defective fuse panel	Replace the relevant fuse panel	8-9
27.	Defective control box interface	Replace the relevant interface	8-9
28.	Defective feeder connection cable	Replace the relevant connection cable	-
29.	Yarn break	Re-thread the feeder	23-24

XD X3 Plus

Fault	Check in the following order
Feeder will not start	1 - 2 - 3 - 4 - 6 - 7 - 8 - 24 - 25 - 26
Feeder will not stop	2 - 4 - 24 - 25
Low or empty yarn store	4 - 3 - 13 - 8 - 21 - 24 - 25 - 27 - 26
Input yarn breaks frequently	22 - 13
Output yarn breaks frequently	11 - 20 - 12 - 19 - 23
Fuses blow repeatedly	25 - 28
Feeder warning light flashes slowly	4
Feeder warning light flashes rapidly	3 - 8 - 27
Feeder warning light continuously on	29

No	Possible causes	Remedies	See page
1.	Incorrect S/Z switch position	Set the S/Z switch in appropriate position	22
2.	Incorrect spoolbody position	Ensure the sensor unit is positioned upwards	26
3.	Winding disc jammed	Free and clean the winding disc	39
4.	Contaminated sensor or mirror	Clean the sensor and mirror using a mild cleaning agent	26
6.	Faulty cable connections	Check and rectify	6, 10-13
7.	Fuses blown	Replace the relevant fuse	10-13
8.	Mains supply / primary voltage fault	Check the mains supply and connections	6, 10-13
11.	Insufficient balloon control	Increase the balloon control	28
12.	Excessive output tension	Reduce the output tension	28
13.	Excessive yarn separation	Reduce the yarn separation	22
19.	Insufficient yarn store	See "low or empty yarn store" under "fault"	-
20.	Damaged balloon control	Repair/replace all defective parts	3
21.	Stop signal fault between control box and weaving M/C	Check all connections/cable	10-13
22.	Misalignment between the bobbin and the feeder	Realign the bobbin/feeder	-
23.	Misalignment between the feeder and the machine	Realign the feeder/machine	-
24.	Defect yarn store sensor unit	Replace the relevant sensor unit	20
25.	Defective motor circuit board	Replace the relevant circuit board	10
26.	Defective fuse panel	Replace the relevant fuse panel	10-13
27.	Defective control box interface	Replace the relevant interface	10-13
28.	Defective feeder connection cable	Replace the relevant connection cable	-
29.	Yarn break	Re-thread the feeder	24

HD X3

Fault	Check in the following order	
	Optical sensor	Mechanical sensor
Feeder will not start	1 - 2 - 3 - 4 - 6 - 7 - 8 - 24 - 25 - 26	1 - 2 - 3 - 5 - 6 - 7 - 8 - 24 - 25 - 26
Feeder will not stop	2 - 4 - 24 - 25	9 - 13 - 5 - 15 - 24 - 25
Low or empty yarn store	4 - 3 - 13 - 9 - 8 - 21 - 24 - 25 - 27 - 26	17 - 3 - 5 - 16 - 13 - 9 - 8 - 21 - 24 - 25 - 27 - 26
Input yarn breaks frequently	22 - 10 - 13	22 - 10 - 18 - 14
Output yarn breaks frequently	11 - 20 - 12 - 19 - 23	11 - 20 - 12 - 19 - 23
Fuses blow repeatedly	25 - 28	25 - 28
Feeder warning light flashes slowly	4	9 - 13
Feeder warning light flashes rapidly	3 - 9 - 8 - 27	3 - 9 - 8 - 27
Feeder warning light continuously on	29	29

No	Possible causes	Remedies	See page
1.	Incorrect S/Z switch position	Set the S/Z switch in appropriate position	22
2.	Incorrect spoolbody position	Ensure the sensor unit is positioned upwards	27
3.	Winding disc jammed	Free and clean the winding disc	39
5.	Sensor arms jammed	Free the arms and clean the sensing unit	39
6.	Faulty cable connections	Check and rectify	6, 10-13
7.	Fuses blown	Replace the relevant fuse	11-13
8.	Mains supply / primary voltage fault	Check the mains supply and connections	6, 10-13
9.	Insufficient input tension	Increase the input tension	-
10.	Excessive input tension	Reduce the input tension	-
11.	Insufficient balloon control	Increase the balloon control	28
12.	Excessive output tension	Reduce the output tension	28
17.	Insufficient max speed setting	Increase the max speed setting	18
18.	Excessive max speed setting	Reduce the max speed setting	18
19.	Insufficient yarn store	See "low or empty yarn store" under "fault"	-
20.	Damaged balloon control	Repair/replace all defective parts	3
22.	Misalignment between the bobbin and the feeder	Realign the bobbin/feeder	-
23.	Misalignment between the feeder and the machine	Realign the feeder/machine	-
24.	Defect yarn store sensor unit	Replace the relevant sensor unit	21
25.	Defective motor circuit board	Replace the relevant circuit board	7
26.	Defective fuse panel	Replace the relevant fuse panel	10-13
27.	Defective control box interface	Replace the relevant interface	10-13
28.	Defective feeder connection cable	Replace the relevant connection cable	-
29.	Yarn break	Re-thread the feeder	25
30.	Sensor out of calibration	Execute automatic sensor calibration	27



EC DECLARATION OF CONFORMITY

IRO AB

Box 54

SE-523 22 Ulricehamn

Guarantee that machine type:

Luna X3, Chrono X3, XD X3, XD X3 Plus and HD X3

is manufactured in conformity with the provisions of the following
EC directives and applicable amendments:

Safety of machinery	2006/42/EC	EN ISO 111 11-1
Low voltage equipment	2014/35/EC	EN ISO 111 11-1
Electromagnetic compatibility	2014/30/EC	EN ISO 111 11-1

Pär Josefsson, Manager Product and Development department, 2016-07-12
