

Ref. no. 40-893G-0401-02/2401

# Operating Instructions

EN |

Luna X4, Chrono X4, XD X4, XD X3 Plus, HD X3

Original language instruction

Warnings .....	3	Threading - pneumatic	
Technical specifications .....	4	Luna X4, Chrono X4, XD X4 .....	23
Mains connection .....	6	Threading - manual	
Operating diagram		Luna X4, Chrono X4, XD X4, XD X3 Plus .....	24
Luna X4, Chrono X4, XD X4 .....	7	Threading - pneumatic and manual	
Connections power supply/ interface		HD X3 .....	25
Luna X4, Chrono X4, XD X4 .....	8	Sensor adjustment	
Connections interface		Chrono X4, XD X4, XD X3 Plus .....	26
Luna X4, Chrono X4, XD X4 .....	9	Luna X4, HD X3 .....	27
Operating diagram		Tension settings/ Balloon control .....	28
XD X3 Plus, HD X3 .....	10	Relaxing ramps	
Connections heavy duty power supply		XD X4, XD X3 Plus, HD X3 .....	29
XD X3 Plus, HD X3 .....	12	Tensioners: Brush .....	30
Connections heavy duty power supply CAN		Tensioners: Flex Brake/ Lamella .....	31
XD X3 Plus, HD X3 .....	13	Tensioners: Brush/ Flex Brake .....	32
Connections power supply/ interface .....	14	Tensioners: RTC .....	33
XD X4 .....	14	Tensioners: TEC .....	37
Installation		Tensioners: CAT .....	38
Luna X4, Chrono X4, XD X4 .....	15	Tensioners: Balloon adjustment .....	39
Dip switch		Tensioners: Funnel .....	40
Luna X4, Chrono X4, XD X4 .....	16	HMI Panel .....	41
Jumpers		TED with Luna X4, Chrono X4, XD X4 .....	43
XD X3 Plus, HD X3 .....	17	ATC with Luna X4, Chrono X4, XD X4 .....	45
Speed settings - feeders with mechanical sensors .....	18	Assembly instructions	
Main parts		Chrono X4, XD X4, XD X3 Plus, HD X3 .....	53
Luna X4, Chrono X4, XD X4 .....	19	Fault finding	
XD X3 Plus .....	20	Luna X4, Chrono X4, XD X4 .....	56
HD X3 .....	21	XD X3 Plus .....	57
S/Z Adjustment .....	22	HD X3 .....	58
		Declaration of conformity .....	59

**This section contains important safety information. Read the manual carefully before installing, using or maintaining the weft feeder.**



**WARNING**

Indicates a possible dangerous situation which could result in serious injury or damage to the unit.



**CAUTION**

Indicates a possible dangerous situation which could result in minor/moderate injury or damage to the unit.

**NOTE**

Used in order to draw attention to important information, which facilitates operation or handling.

**WARNING!**











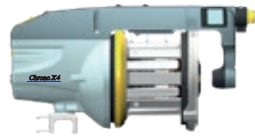
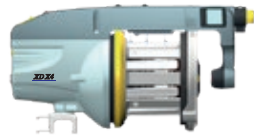





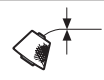

- The power supply must be switched off at the mains before any work is carried out on the feeder, the transformer/interface or any other electrical components. The feeder and the transformer cabinet and cable covers must be fully assembled before the power supply is connected.
- The weft feeder ON/OFF-switch DO NOT cut off the main power supply. Turn off the main switch before any work is carried out on the electrical circuit.
- The feeder and transformer contain electrical components that retain an electric current up to three minutes after disconnection. DO NOT open or disconnect feeder or interface, including cables, within this time.
- All work on electrical components must be carried out by a qualified electrician.
- This product is not intended for use in potentially explosive atmospheres or in zones classified according to the European directive 2014/34/EU. Please contact Vandewiele Sweden AB or ROJ Srl if products for use in a potentially explosive atmosphere are required.
- Always turn off the main switch or isolate the power supply and disconnect the air supply before connecting or disconnecting the feeder, the control board or any of the circuit boards
- Routine checks for damaged or worn parts must be made before operating this equipment. Any part that is worn or damaged should be properly repaired or replaced by authorized personnel. To avoid risk of injury DO NOT operate this equipment if any component does not appear to be functioning correctly.
- Take necessary precautions to avoid injuries when interacting with the product. Use suitable respiratory and eye protection.
- Improper handling at repair, fault finding or similar may damage the feeder/interface mechanical/electrical components including cables and connectors. DO NOT perform measurements on feeder electrical components and parts. Please contact your local IRO or ROJ service station for further information.

**CAUTION!**

- Caution must be taken in the close vicinity of the feeder as it contains moving parts that can cause injuries and, in normal operation, starts without prior warning.
- To comply with C.E. Regulations only replacement parts approved by Vandewiele Sweden AB or ROJ Srl may be used.
- The feeder is an industrial product and therefore not approved to use household environments /in residential areas.

**NOTE**

- To ensure the selection of the most suitable feeder and associated accessories, it is recommended making weaving tests with the intended yarns.
- Please dispose of obsolete or unwanted equipment responsibly, taking into consideration any local regulations regarding the disposal and / or recycling of materials that are applicable.
- All products in this manual may not be available for your market.
- The performance of a tensioner can be affected by various factors connected to the specific yarns being used. In case of uncertainty it is recommended to carry out a weft insertion test.

	Luna X4	Chrono X4	XD X4
			
	Max 2000 m/min	Max 2000 m/min	Max 2000 m/min
	6.5 kg	8.6 kg	8.6 kg
	Min 5° C - Max 40° C	Min 5° C - Max 40° C	Min 5° C - Max 40° C
	RH max 85 %	RH max 85 %	RH max 85 %
	Sound pressure $L_{pa}$ 59 dB (A), Sound power $L_{Wa}$ 72 dB (A)	Sound pressure $L_{pa}$ 73 dB (A), Sound power $L_{Wa}$ 87 dB (A)	Sound pressure $L_{pa}$ 74 dB (A), Sound power $L_{Wa}$ 88 dB (A)
	Ø max 5 mm	Ø max 5 mm	Ø max 5 mm
	Input air pressure 5,5 - 7 bar	Input air pressure 5,5 - 7 bar	Input air pressure 5,5 - 7 bar
	Max 2,7 mm	Max 4 mm	Max 4 mm
<b>Power Supply / Interface</b>			
		200 - 575V 400VA	200 - 575V 400VA
	 Fuse	Max T 10A	Max T 10A
		3,3 kg	3,3 kg
<b>Interface</b>			
		Power supply via loom/ weaving machine	Power supply via loom/ weaving machine
		1,4 kg	1,4 kg
<b>Extension Interface</b>			
		Power via Power Supply/ Interface connected to extension plug	Power via Power Supply/ Interface connected to extension plug
		1,4 kg	1,4 kg

**NOTE**

Subject to technical modifications.



**WARNING!**

Hearing protection must be worn when operating this equipment.

	XD X3 Plus	HD X3	
	Max 1600 m/min	1600 m/min	
	11,5 kg	12,8 kg	
	Min 5° C - Max 40° C	Min 5° C - Max 40° C	
	RH max 95 %	RH max 95 %	
	Sound pressure $L_{pa}$ 67,1 dB (A), Sound power $L_{Wa}$ 79,5 dB (A)	Sound pressure $L_{pa}$ 67,1 dB (A), Sound power $L_{Wa}$ 79,5 dB (A)	
	Ø max 11 mm	Ø max 11 mm	
	Input air pressure 5,5 - 7 bar	Input air pressure 5,5 - 7 bar	
	Max 4 mm	Max 4 mm	
<b>Heavy Duty Power Supply Stand Alone</b>			
		230-575V 1000VA	230-575V 1000VA
	 Fuse	Max T 10A	Max T 10A
		21 kg	21 kg
<b>Heavy Duty Power Supply CAN</b>			
		380-440V 1900VA	380-440V 1900VA
		Max T 10A	Max T 10A
		35 kg	35 kg

**NOTE**

Subject to technical modifications.



**WARNING!**

Hearing protection must be worn when operating this equipment.

**NOTE**

Condensation can form on the weft feeder when it is moved from the cold environment of the warehouse to the warmer environment of the loom room. Make sure that the feeder is dry before switching it on.



**WARNING!**

Turn off the main switch before any work is carried out on the electrical circuit.

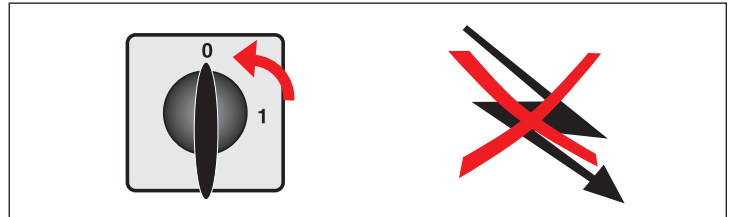

**NOTE**

Make sure that the cable covers are tight.



Take the Voltage Supply Box out of the packing. Open the cover and connect the three-phase power cord. (4-wires cable). Make sure that the earth connection is properly made. The section of each wire cannot be less than 1,5 mm<sup>2</sup>.

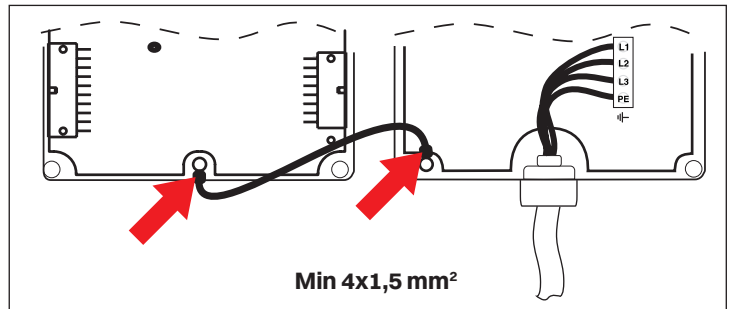

The power supply to the feeder must not be disrupted when the weaving machine stops.

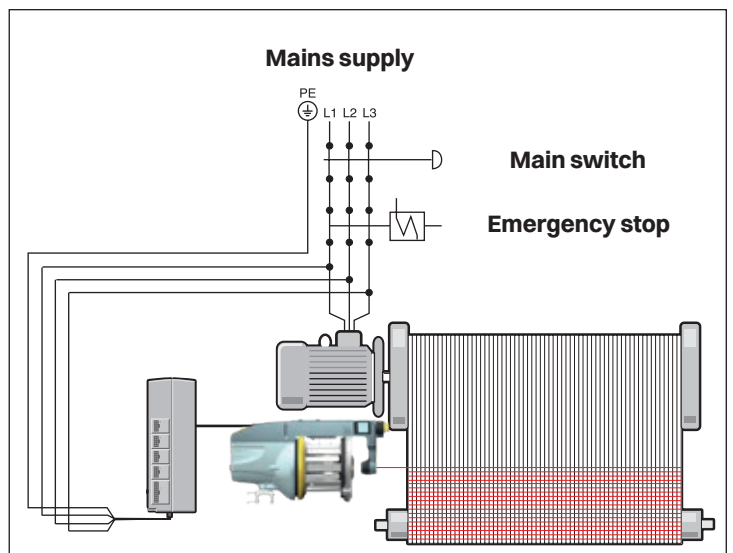

Variations in main voltage.

Nominal	Voltage	Frequency
200V - 346V	180V - 380V	50/ 60 Hz
380V - 400V	342V - 440V	50/ 60 Hz
415V - 575V	374V - 632V	50/ 60 Hz

Luna X4, Chrono X4, XD X4

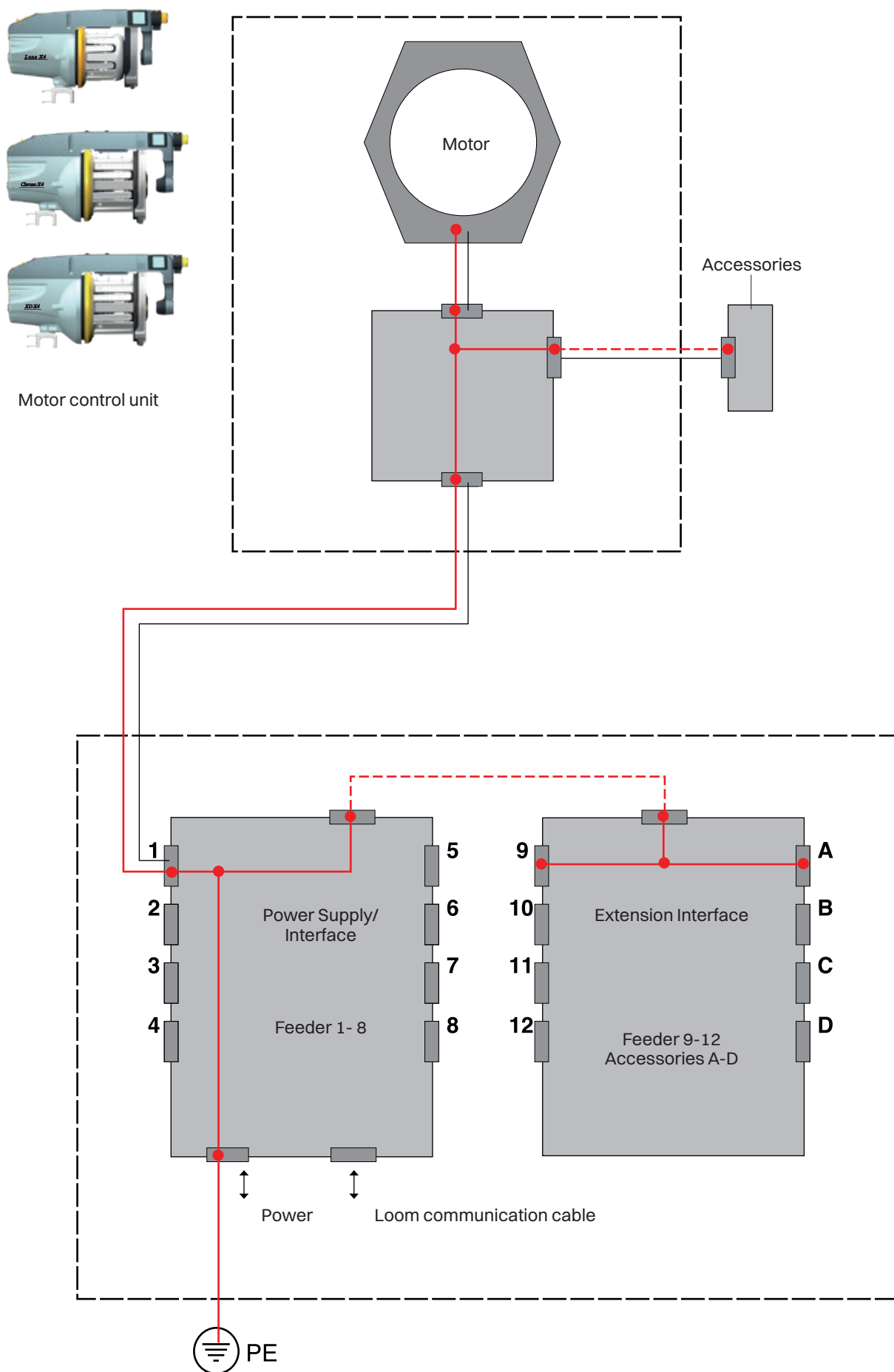

Luna X4, Chrono X4, XD X4



Power Supply/ Interface

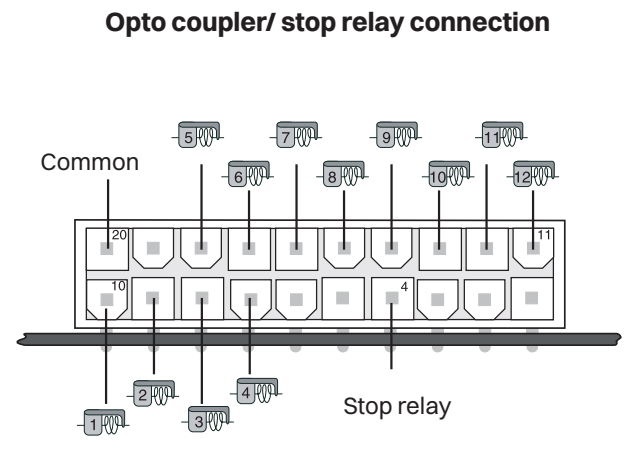
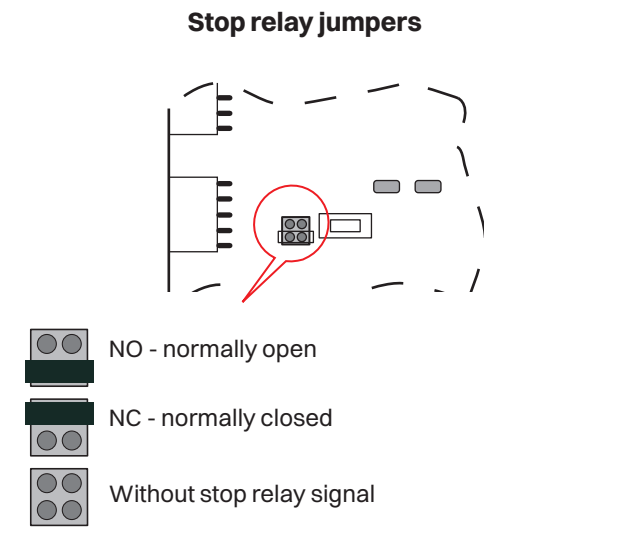
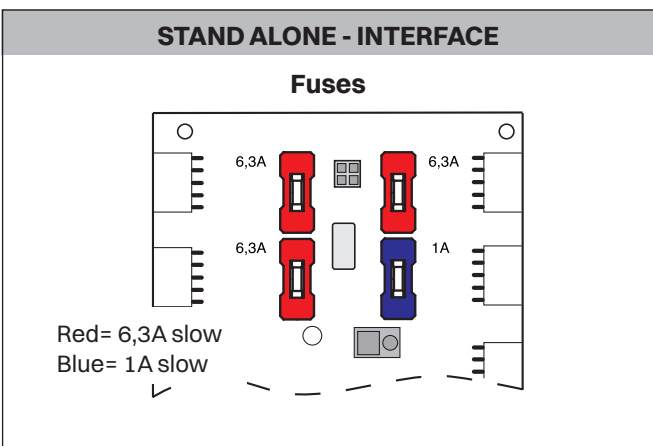
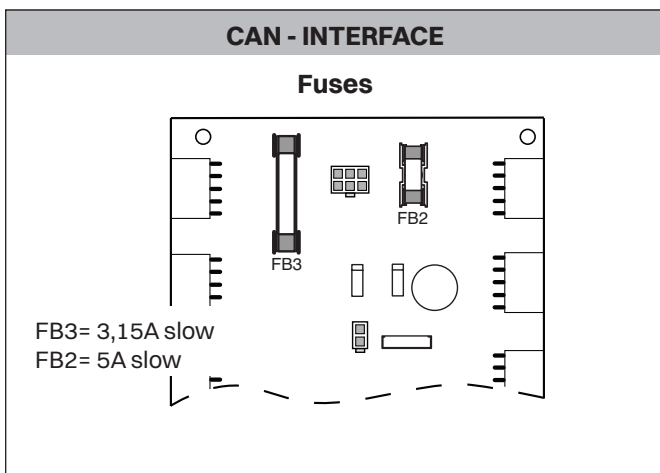
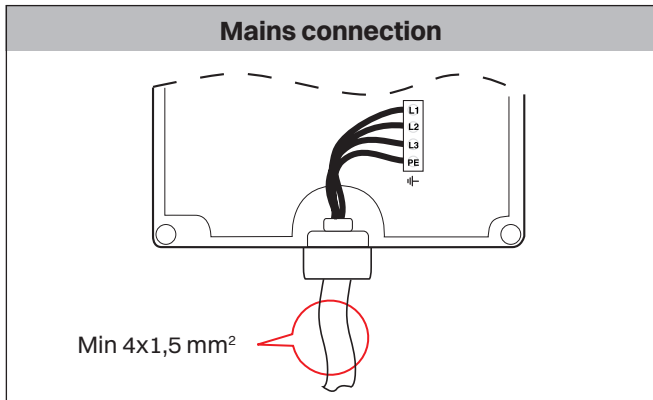



Luna X4, Chrono X4, XD X4



Interface  
Power supplied via loom

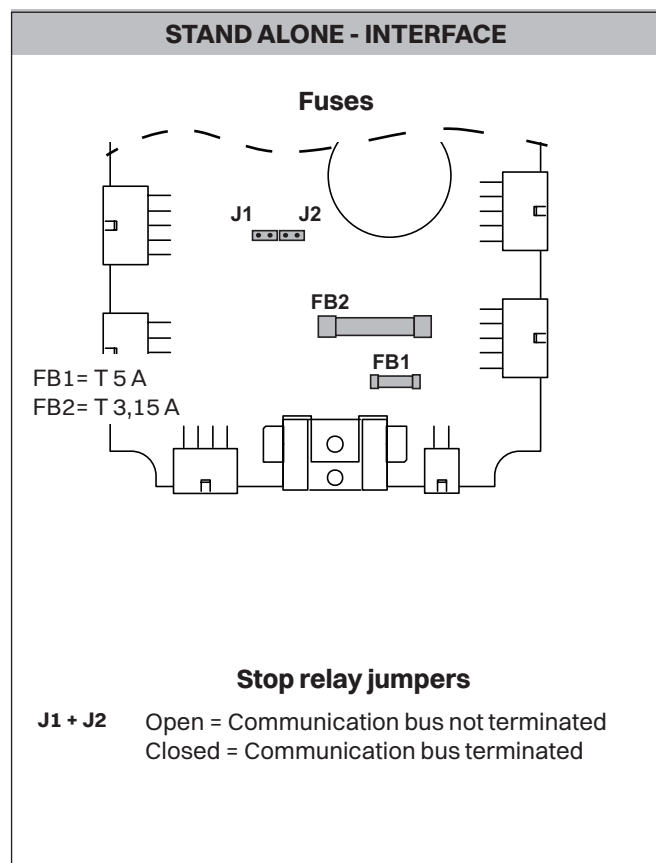
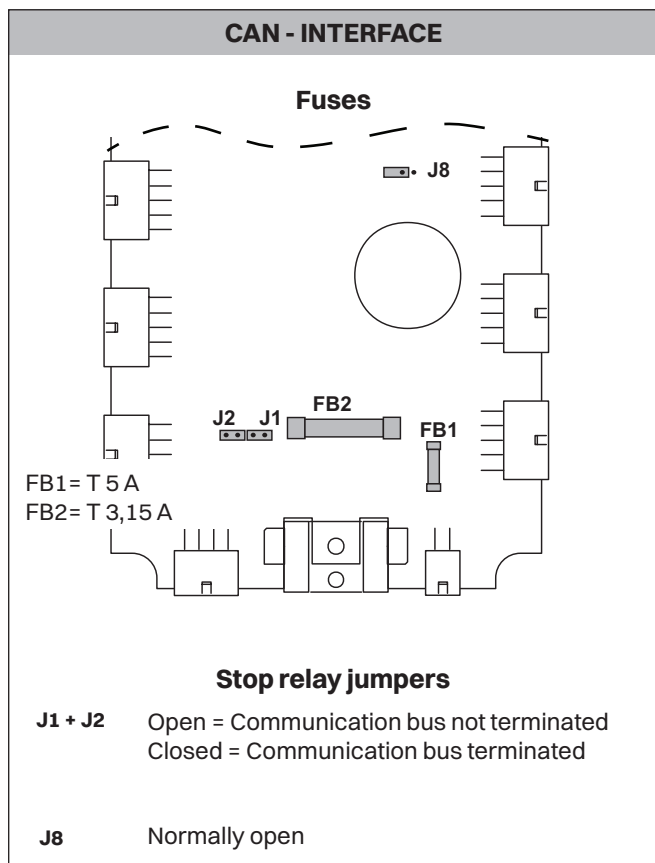

**XD X3 Plus, HD X3**

Connect the feeders' cable to the voltage supply box by following the numeric correspondence to the color selector's needles.

**NOTE**

**Feeder working with the weft threaded in the needle 1 must be connected to the position 1 of the voltage supply box; etc.**

Connect the signal cable coming from the voltage supply box to the loom.

Connect the plug of the 3-phase power cord to the socket available to the loom panel.

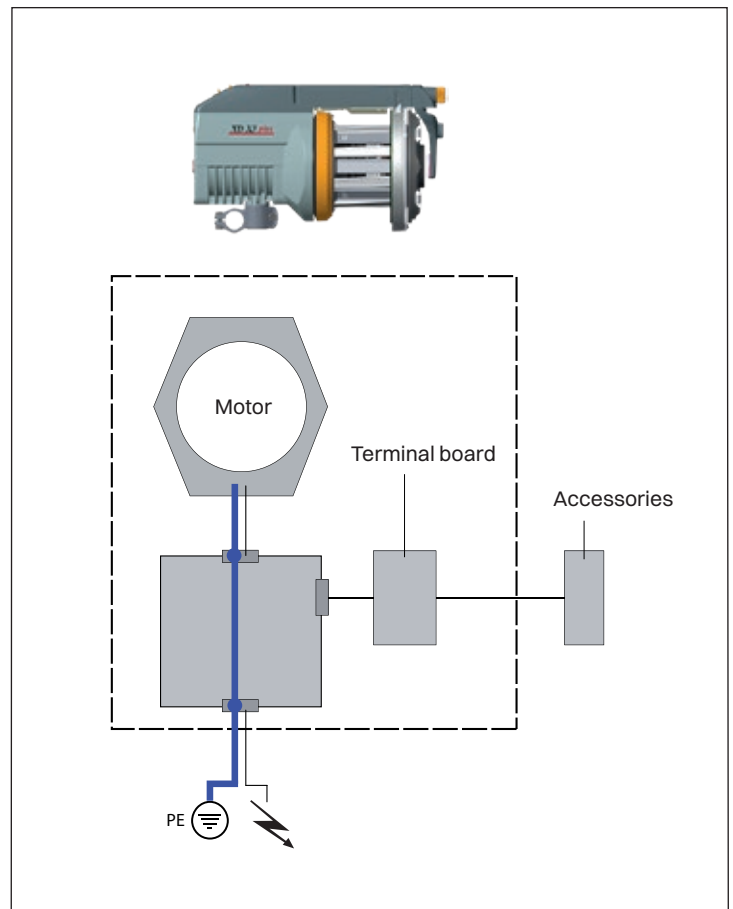

**HD X3**

**HD POWER SUPPLY /  
CAN INTERFACE**

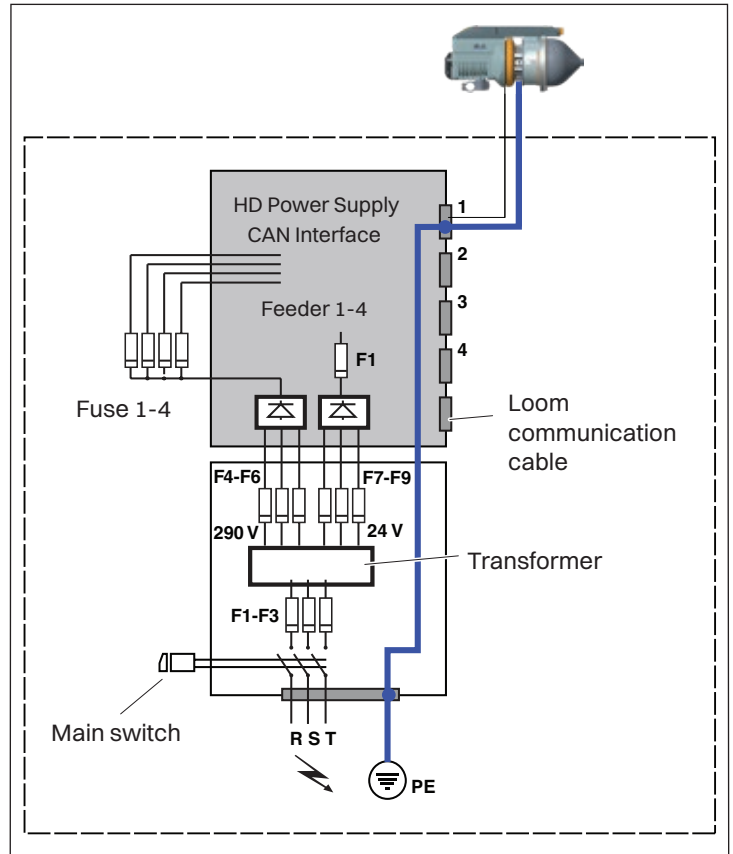

**XD X3 Plus, HD X3**

**HD POWER SUPPLY /  
STAND ALONE INTERFACE**

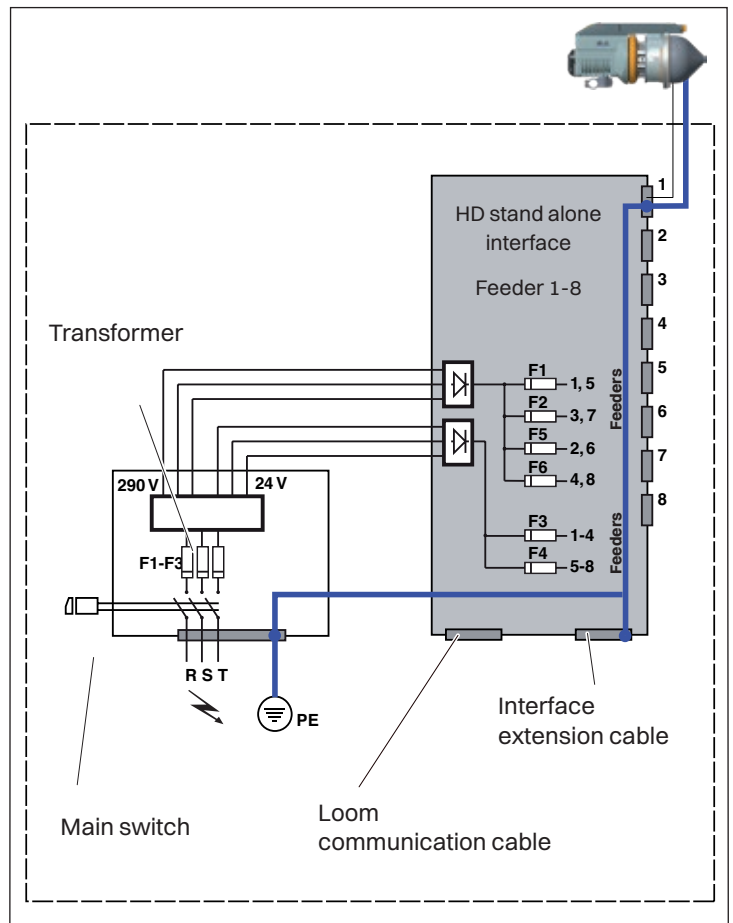

**XD X3 Plus, HD X3**

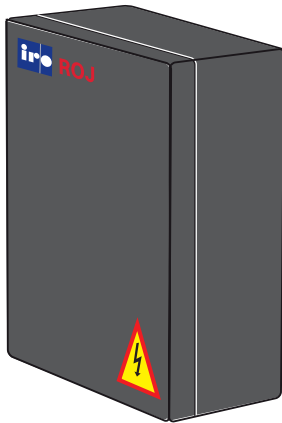

**Heavy Duty Power Supply Stand Alone**

**STAND ALONE - POWER SUPPLY**

**Fuses**

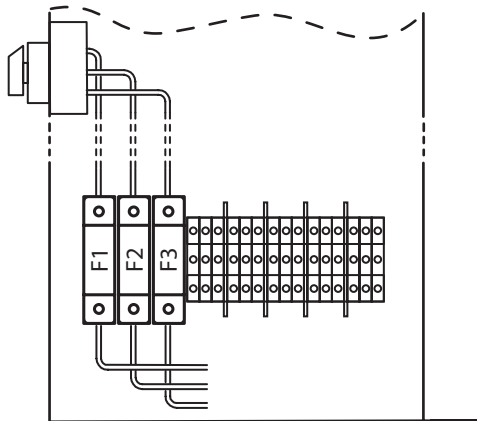

F1 - F3 = 4 A / 500 V

**Mains connection**

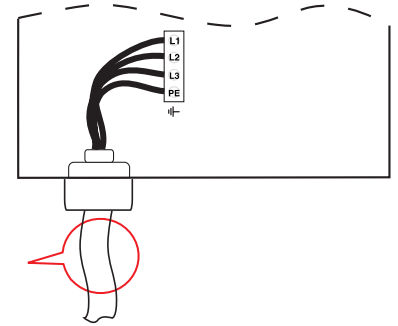

Min 4x1,5 mm<sup>2</sup>

**STAND ALONE - INTERFACE**

**Fuses**

Red= 6,3A slow  
Blue= 6,3 A slow

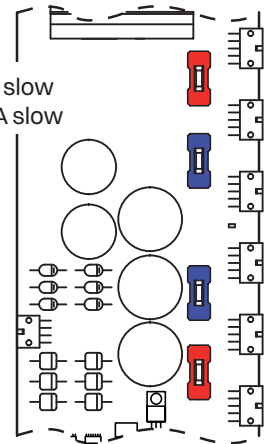

**Stop relay jumpers**

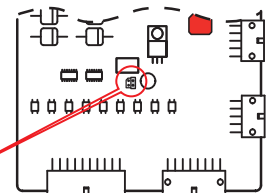

NO - normally open



NC - normally closed



Without stop relay signal

**Opto coupler/ stop relay connection**

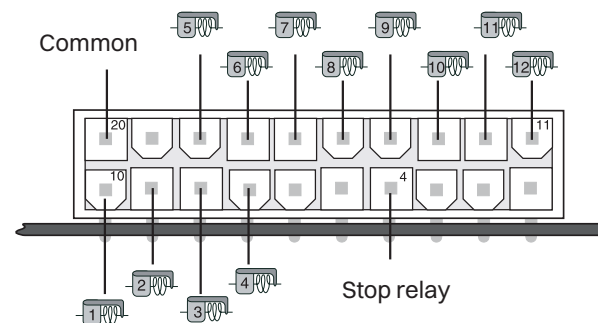

**XD X3 Plus, HD X3**

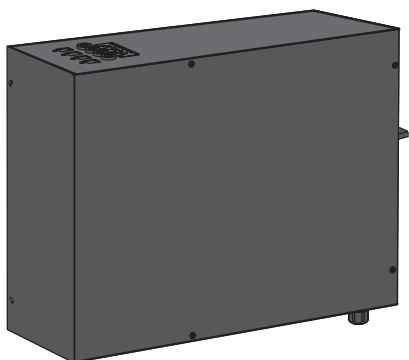

**Heavy Duty Power Supply CAN**

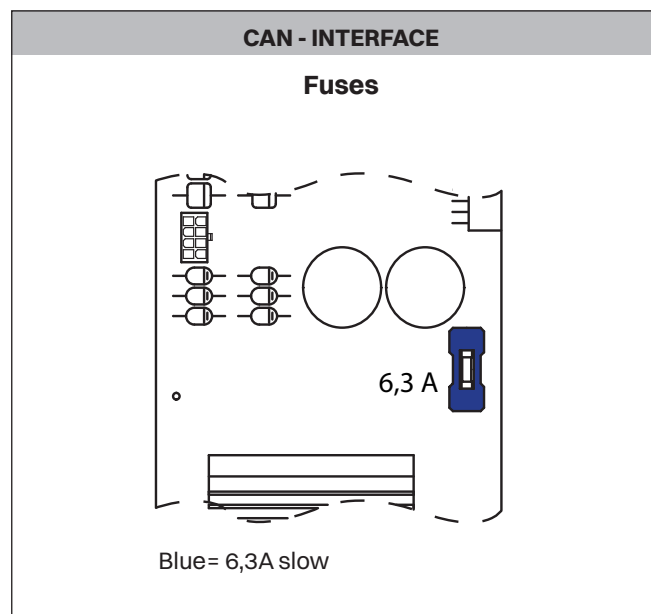
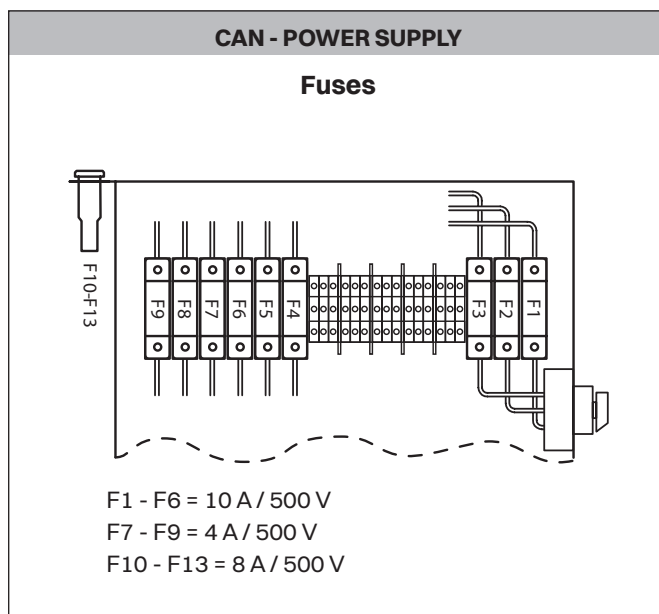
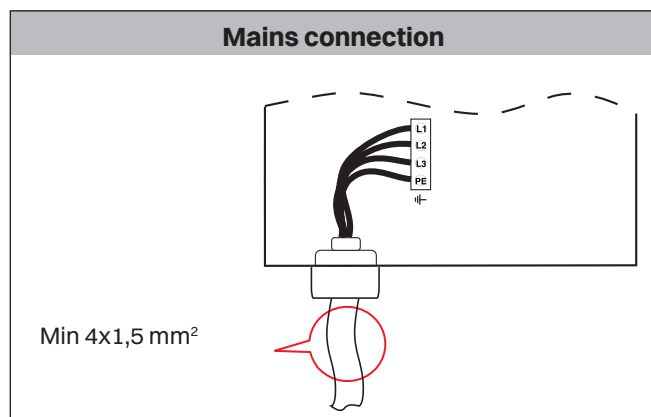

**XD X4**



**Power Supply/ Interface**

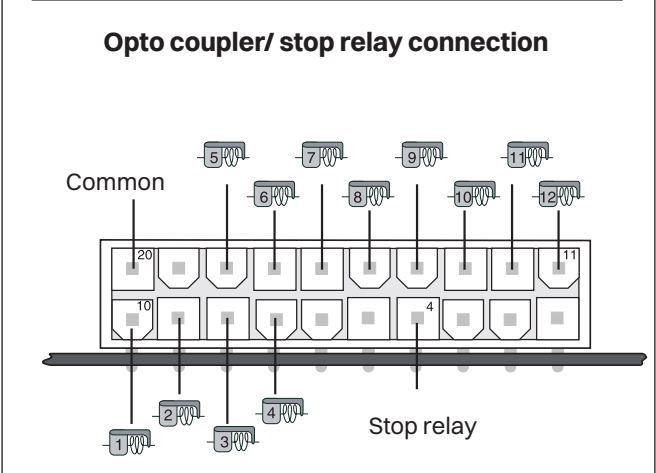
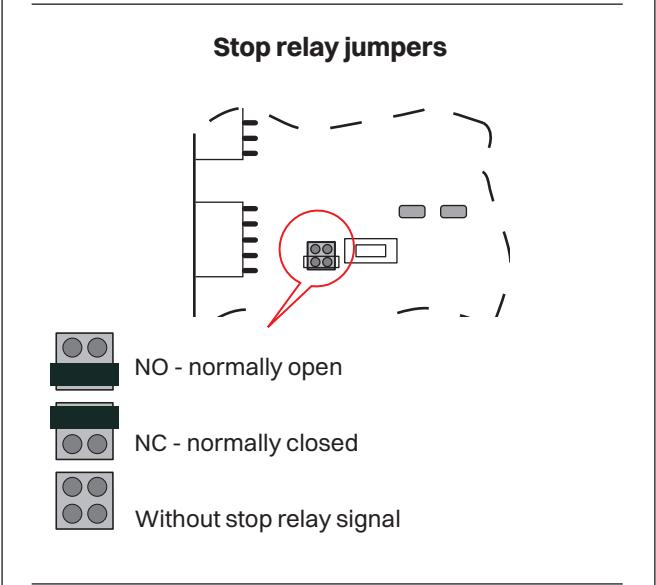
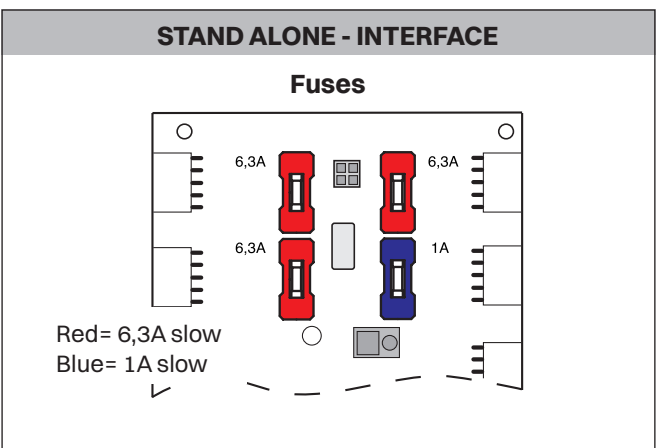
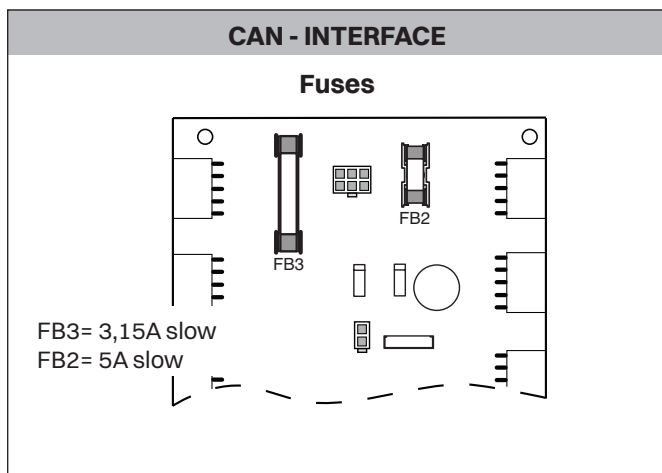
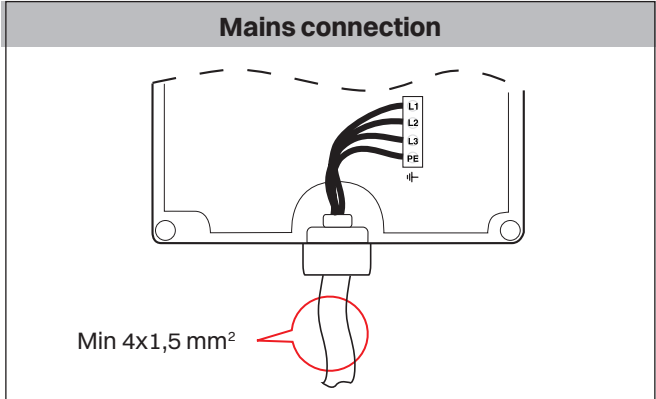

**NOTE**

Condensation can form on the weft feeder when it is moved from the cold environment of the warehouse to the warmer environment of the loom room. Make sure that the feeder is dry before switching it on.



**CAUTION!**

The unit should not be mounted directly on the weaving machine.

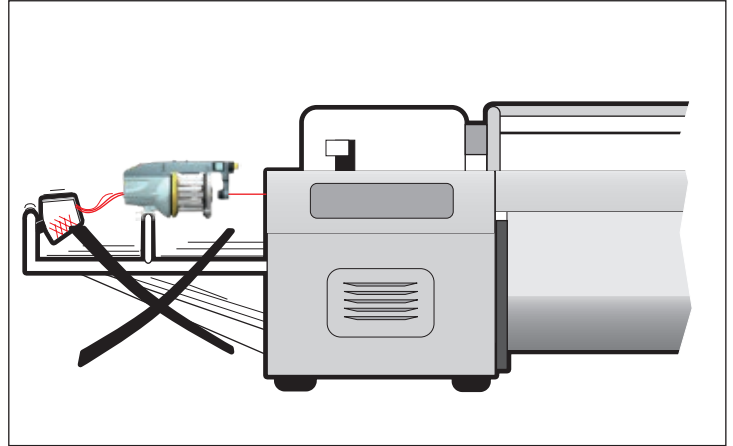

Use a separate floor stand.

**NOTE**

Feeders' stand and creel must be connected to the earth of the loom.

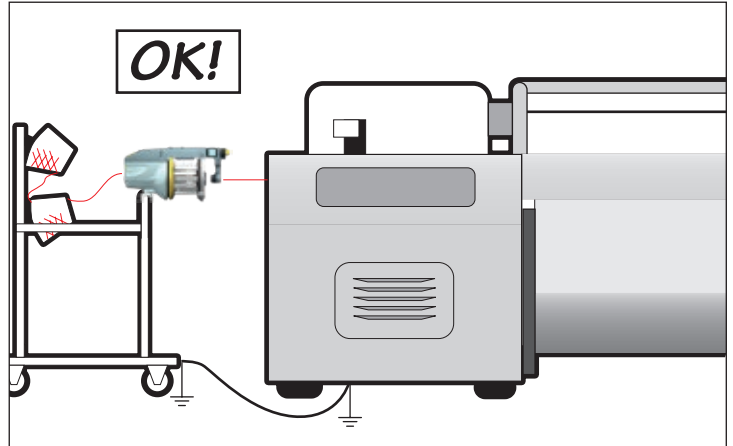

**NOTE**

Place the creel behind the feeder's stand avoiding sharp angles to the yarn path from the creel output to the feeders.

Feeders with Mechanical sensors must be mounted within 45° of the horizontal plane.

\* Max 15° with low sensor spring force.(see page 26)

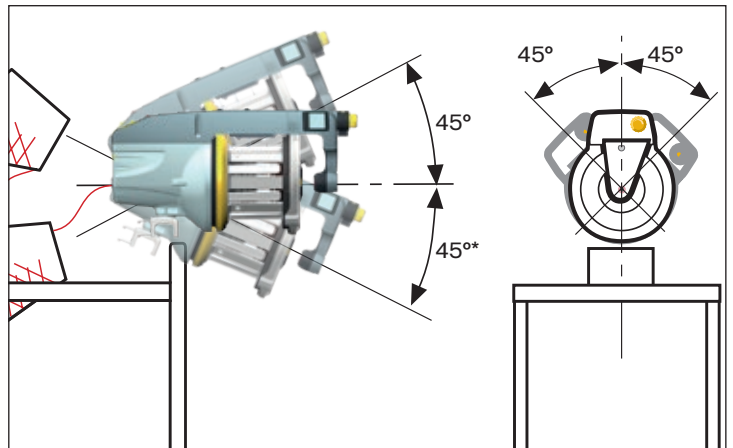

Ensure that the mount screws are correctly tightened.

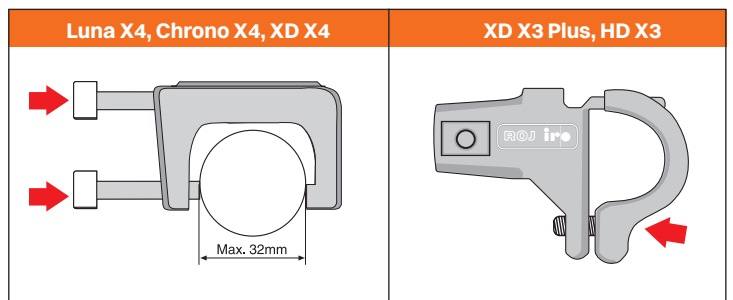

Luna X4, Chrono X4, XD X4

The feeder is equipped with dip switch on the motor circuit board that adapt the feeders operation to the characteristics of the weaving process. (Weaving machine settings have priority over dip switch settings).

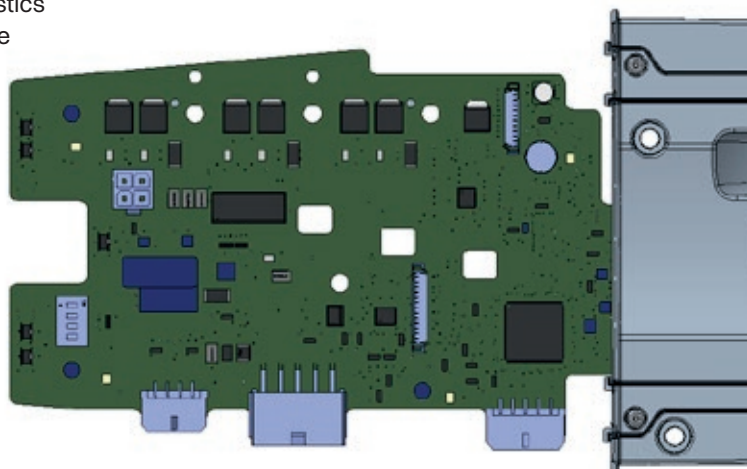

	Opto sensors	Mech. sensors
<b>J1</b> 	Yarn store sensor sensitivity - LOW	Yarn break sensor filtering - RIGID YARNS
<b>J1</b> 	Yarn store sensor sensitivity - AUTO	Yarn break sensor filtering - NORMAL
<b>J2</b> 	Integrated yarn break sensor - DISABLE	Integrated yarn break sensor - DISABLE
<b>J2</b> 	Integrated yarn break sensor- ENABLE	Integrated yarn break sensor - ENABLE
<b>J3</b> 	Winding disc positioning - DISABLE (one way bearing)	Winding disc positioning - DISABLE (one way bearing)
<b>J3</b> 	Winding disc positioning - ENABLE	Winding disc positioning - ENABLE
<b>J4</b> 	Pattern in advance - DISABLED	Pattern in advance - DISABLED
<b>J4</b> 	Pattern in advance - ENABLED	Pattern in advance - ENABLED



**XD X3 Plus, HD X3**

The feeder is equipped with jumpers on the motor circuit board that adapt the feeders operation to the characteristics of the weaving process. (Weaving machine settings have priority over jumper settings).

	XD X3 Plus	HD X3
J1	Yarn store sensor sensitivity- LOW (Normal setting XD X3 Plus)	-
J1	Yarn store sensor sensitivity- AUTO	-
J2	Integrated yarn break sensor- DISABLE	-
J2	Integrated yarn break sensor- ENABLE	-
J3	Winding disc positioning- DISABLE (ONE WAY BEARING)	Winding disc positioning- DISABLE (ONE WAY BEARING)
J3	Winding disc positioning- ENABLE	Winding disc positioning- ENABLE
J4	Pattern in advance- DISABLE	Pattern in advance- DISABLE
J4	Pattern in advance- ENABLE	Pattern in advance- ENABLE
		<p><b>NOTE</b></p> <p><b>Whenever the electronic board or the sensors board are replaced, it is necessary to carry out the “Automatic sensor calibration procedure”.</b></p>

To set the maximum speed rotate the disc to the appropriate position.

**NOTE**

Normally the switch should be left at position 1 since the feeder automatically calculates the speed according to yarn consumption. However, with very low speeds or wide looms, it could be helpful to reduce the maximum speed in order to avoid unnecessary acceleration

	Luna X4	Chrono X4	XD X4
	1 = 2000 m/min 2 = 1600 m/min 3 = 1050 m/min 4 = 650 m/min	1 = 2000 m/min 2 = 1600 m/min 3 = 1050 m/min 4 = 650 m/min	1 = 2000 m/min 2 = 1600 m/min 3 = 1050 m/min 4 = 650 m/min
	XD X3 Plus	HD X3	
	1 = 1600 m/min 2 = 1300 m/min 3 = 1100 m/min 4 = 900 m/min	1 = 1600 m/min 2 = 1300 m/min 3 = 1100 m/min 4 = 900 m/min	

Luna X4, Chrono X4, XD X4

**NOTE**

Do not expose the brush ring holder or the winding disc to external forces as this may cause damage / deformation.

Do not, for instance, carry the feeder by holding it in the brush ring holder.

Store the feeder resting on the back or top cover to avoid damaging / deforming mentioned parts.

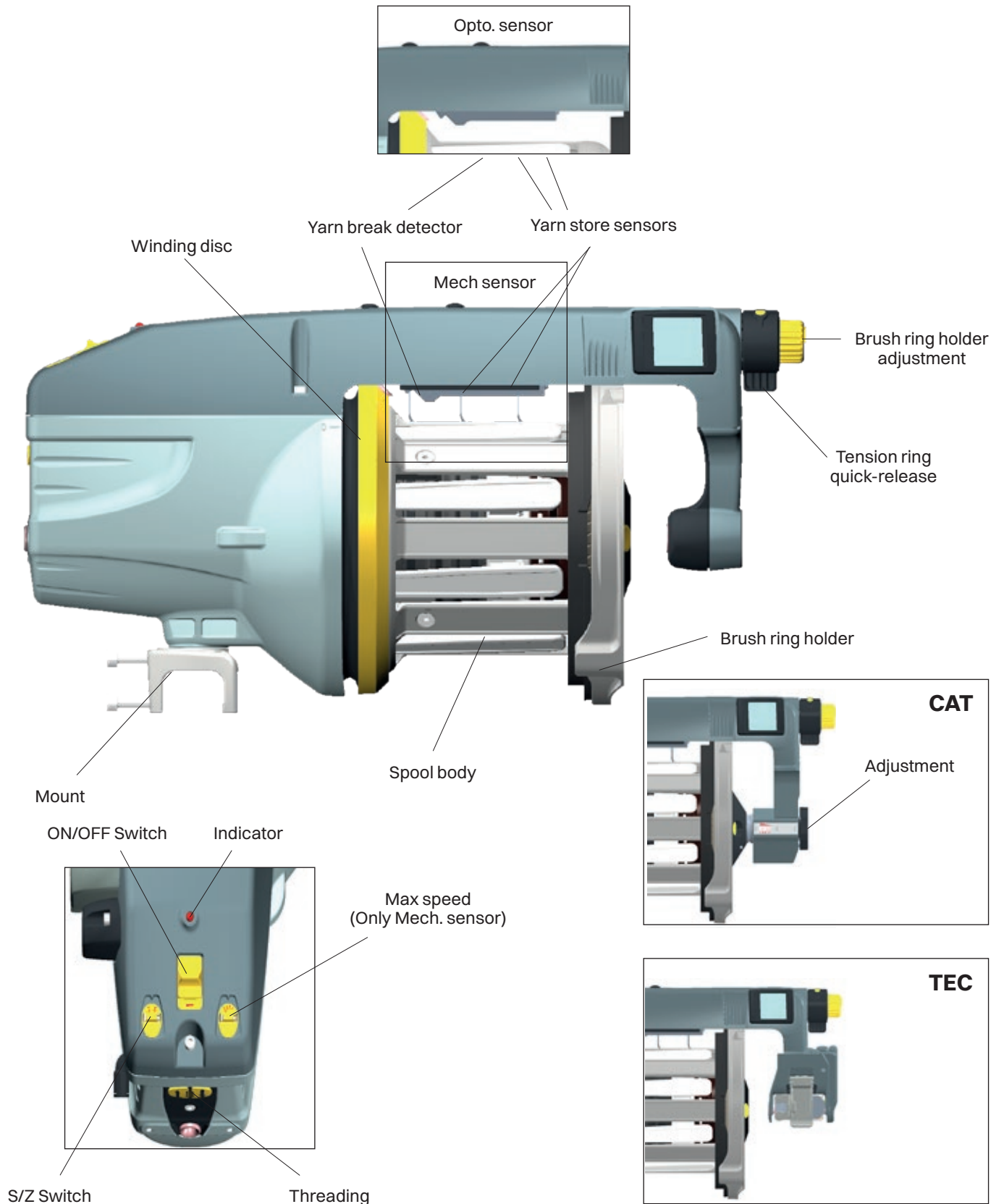

**XD X3 Plus**

**NOTE**

Do not expose the brush ring holder or the winding disc to external forces as this may cause damage / deformation.  
 Do not, for instance, carry the feeder by holding it in the brush ring holder.  
 Store the feeder resting on the back or top cover to avoid damaging / deforming mentioned parts.

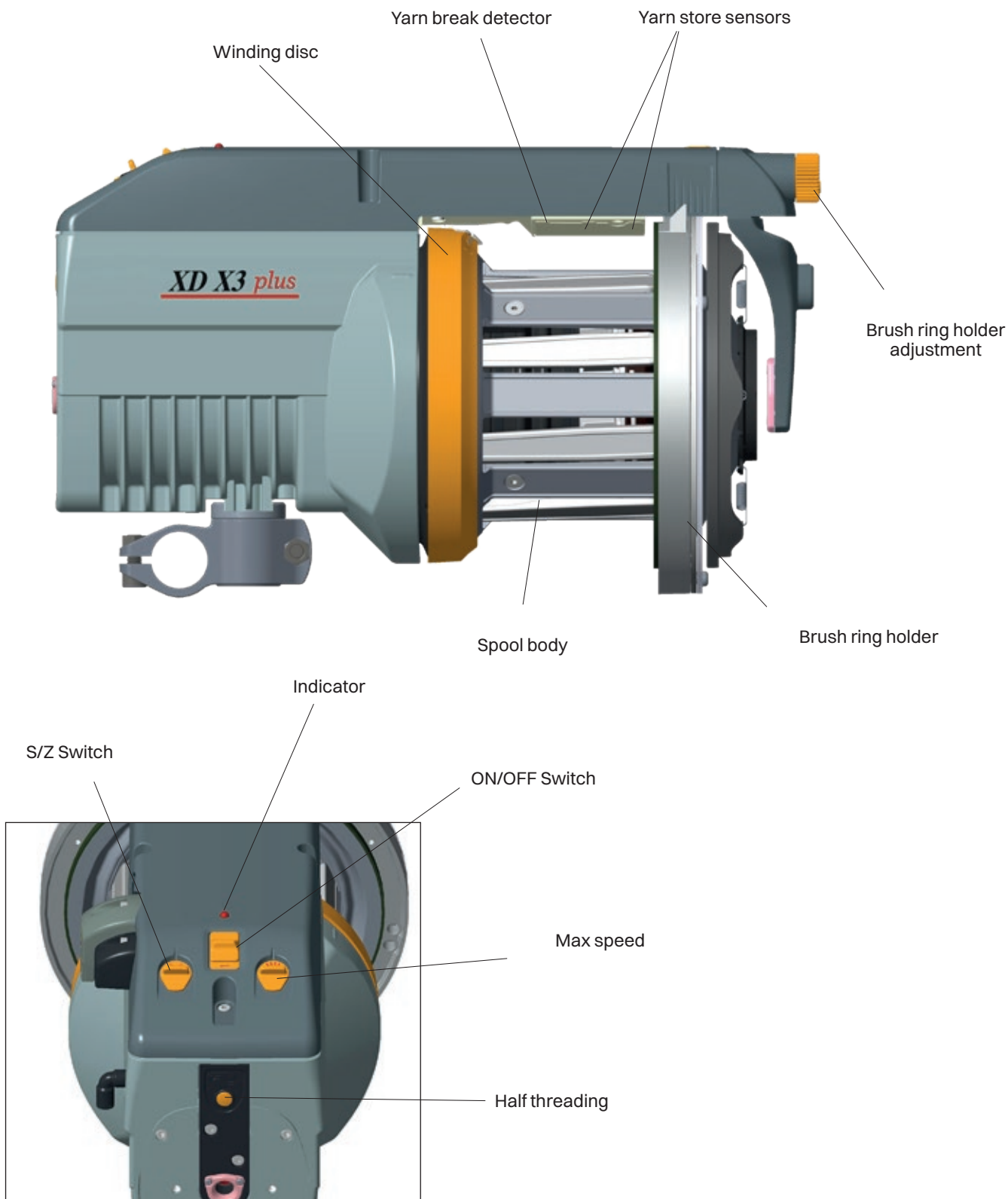

HD X3

**NOTE**

Do not expose the brush ring holder or the winding disc to external forces as this may cause damage / deformation.  
 Do not, for instance, carry the feeder by holding it in the brush ring holder.  
 Store the feeder resting on the back or top cover to avoid damaging / deforming mentioned parts.

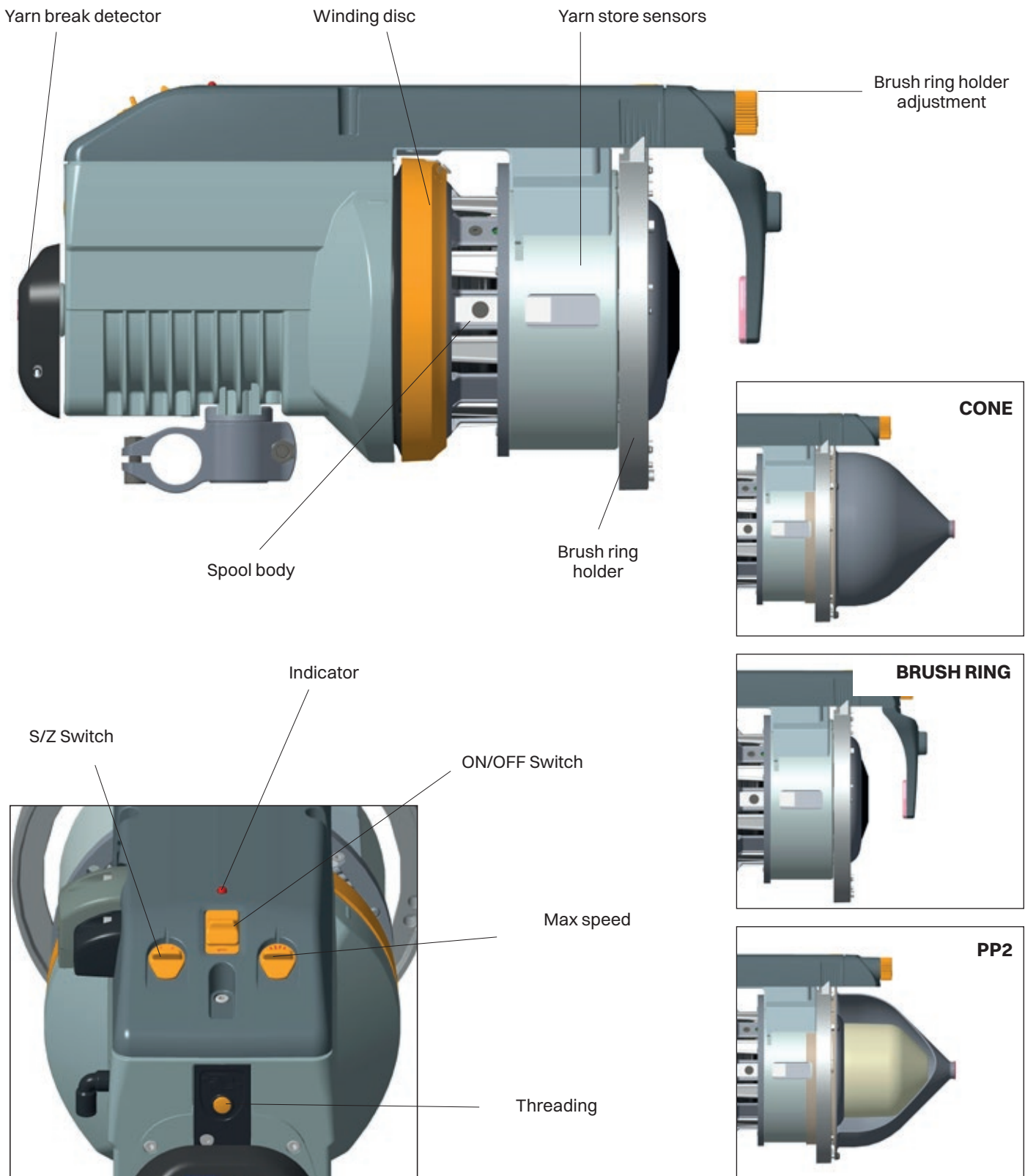

Switch off the feeder.

On feeders with S-flex, the S-flex must be detached for making the S/Z adjustment.  
See page 31-32 (Flex-brake mounting).



Grip the winding disc and, whilst pressing the orange button on the front of the spool body, rotate the disc until the button is felt to locate. Aligning the mark on the winding disc with the line on the motor house gives the zero separation position.

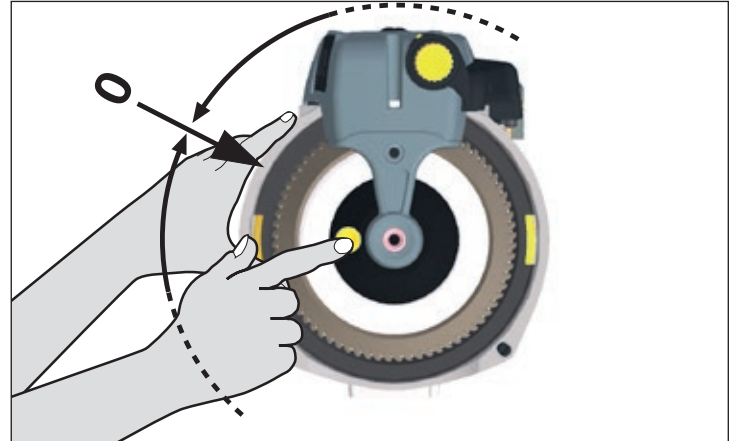

To adjust, press in the button and revolve the winding disc in the appropriate direction. The separation increases from 0 to 4 mm the more the disc is rotated.

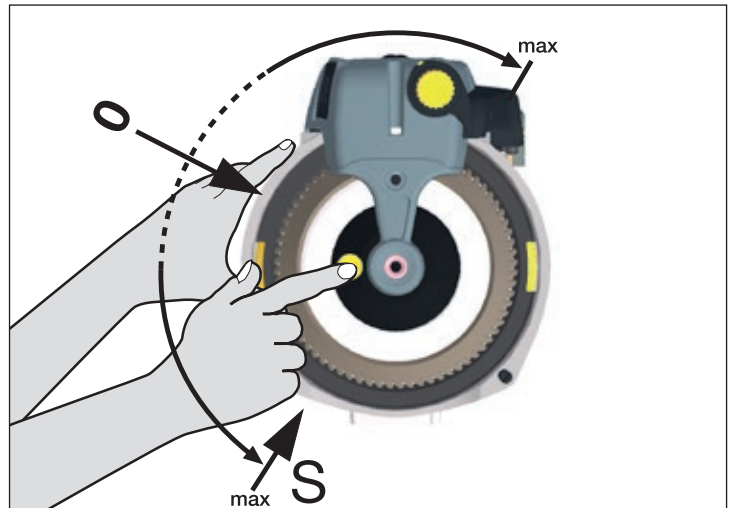

**NOTE**

Before starting the automatic sensors calibration, check the following:

The separation must be distinct, but not excessive.

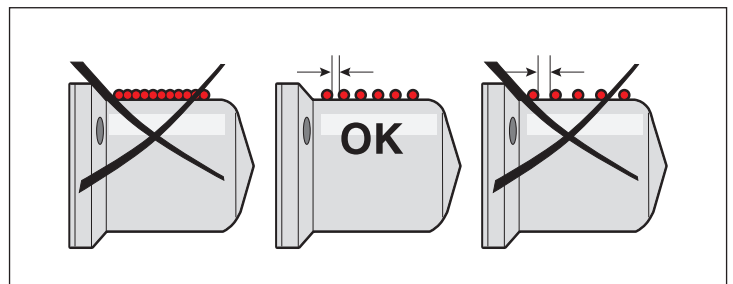

Set the direction of rotation with the switch. (The feeder is deactivated in the standby position (0))

**NOTE**

On feeders with brush, choose the correct type of brush (S, Z or Straight) depending on the direction of the rotation. See page: 32

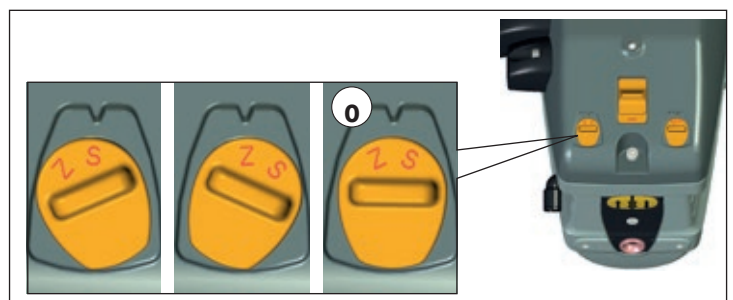

Luna X4, Chrono X4, XD X4

**FULL THREADING, AUTOMATIC SLIDE SHIFT**

- Restart the feeder to automatically position the winding disc (empty spool body)
- Press the OCB button on the top off the ATC motor module (1) to open the quick release function.
- Insert the yarn into the eyelet and press both buttons, whilst lightly holding the yarn.
- Press the OCB button to close the quick release function.

**NOTE**

Only when ATC is attached.

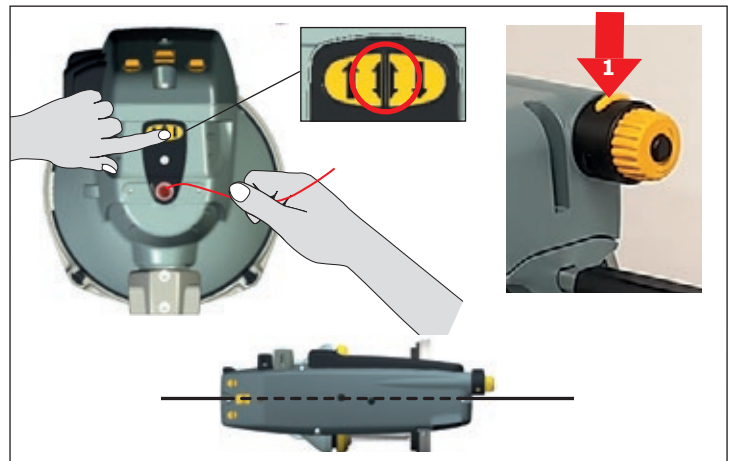

**FULL THREADING, MANUAL SLIDE SHIFT**

- Restart the feeder to automatically position the winding disc (empty spool body)
- Open the brush holder, see page 30.
- Insert the yarn into the eyelet and press both the buttons, whilst lightly holding the yarn.

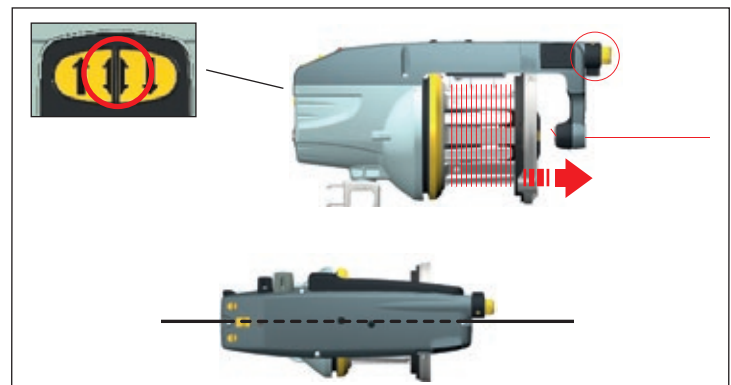

**HALF THREADING, FRONT**

Insert the yarn into the eyelet and press the left button, whilst lightly holding the yarn.

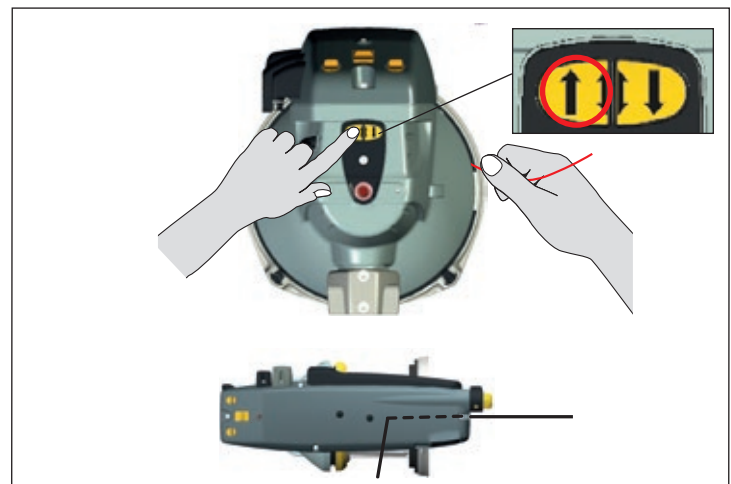

Luna X4, Chrono X4, XD X4

**WITHOUT CAT**

- Switch off the feeder.
- Align the winding disc eyelet (1).
- Open the brush holder (see page 30,32).
- Thread the needle all the way through the feeder and output eyelet.
- Pull the yarn through.
- Restart the feeder.

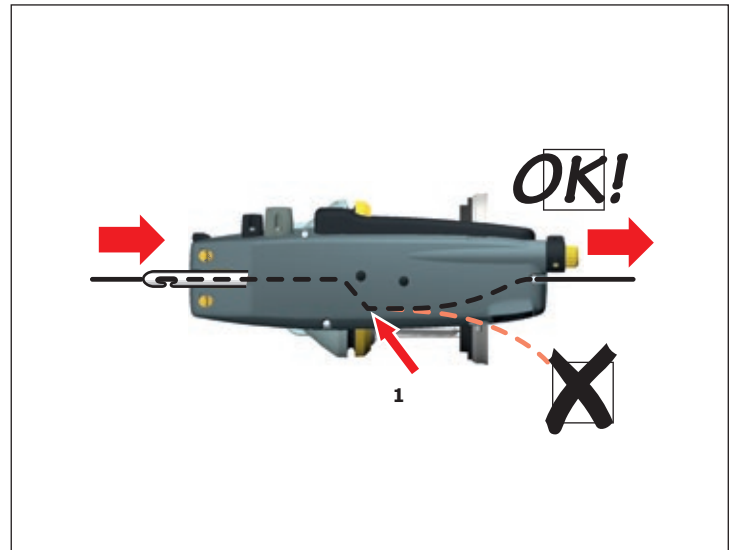

**WITH CAT**

- Switch off the feeder.
- Align the winding disc eyelet.
- Thread the needle through the feeder and balloon control brush.
- Start the feeder and fill the yarn store.
- Insert the threading needle into the CAT (2) as far as possible.
- Pulling the yarn (3) will cause it to wrap around the threading needle.
- When the threading needle is pulled out (4) the yarn will follow.

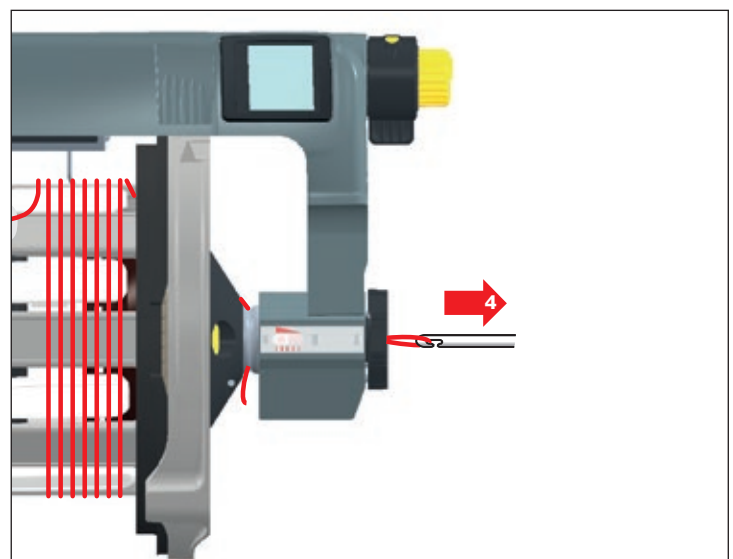
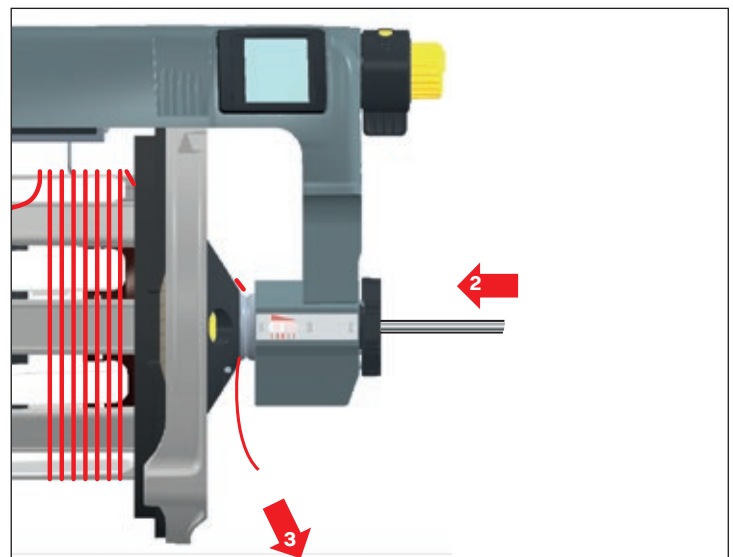

**WARNING**

When using a threading needle, care must be taken to avoid damaging the Flex brake. Ensure that the flex holder is in the forward position before threading.



HD X3, XD X3 Plus

Switch on the feeder.  
The winding disc will automatically position itself (empty spool body).

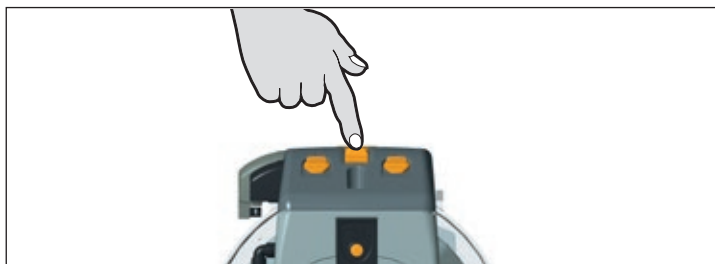

**HALF THREADING**

Insert the yarn into the eyelet and press the button, whilst lightly holding the yarn.

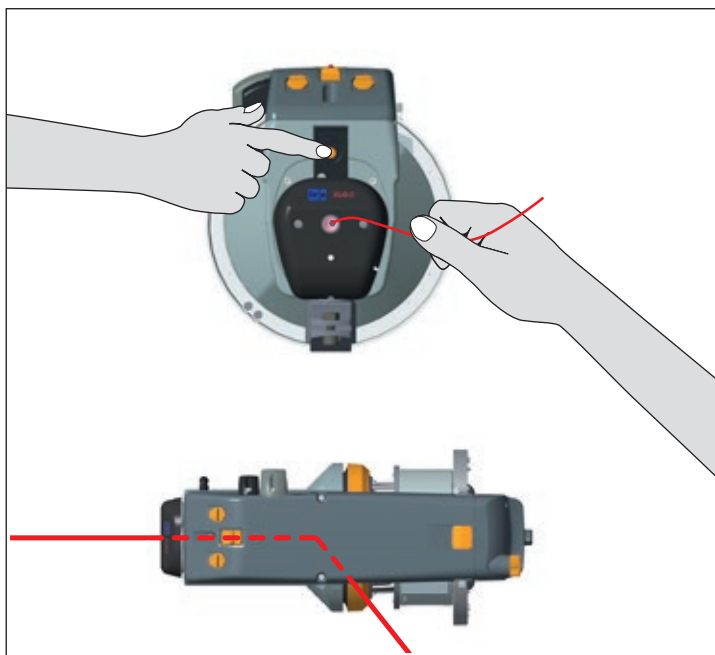

**MANUAL THREADING**

1. Align the winding disc eyelet (1).
2. Open the brush holder (see page 32).
3. Thread the needle all the way through the feeder and output eyelet.
4. Pull the yarn through.
5. Restart the feeder.

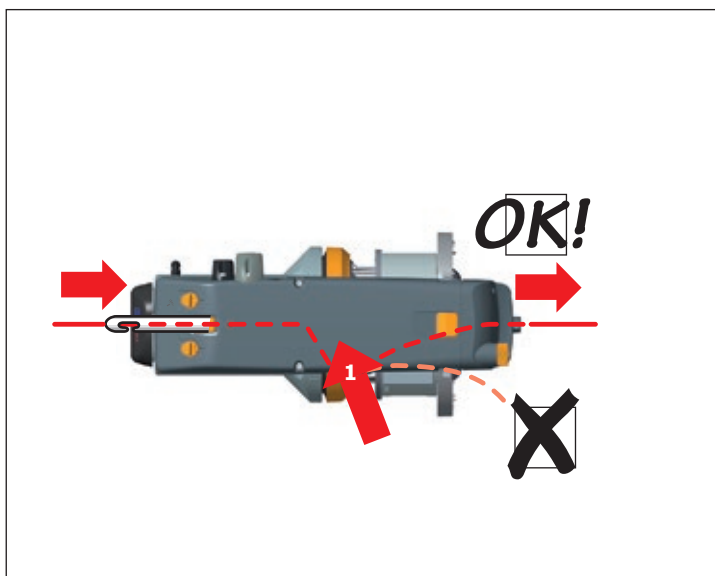

**WARNING**

When using a threading needle, care must be taken to avoid damaging the Flex brake. Ensure that the flex holder is in the forward position before threading.

Chrono X4, XD X4, XD X3 Plus

1. Ensure that the spoolbody sensor part is in the correct position

Optical sensors

2. Certain yarn types may stick to, or leave deposits on, the sensor mirror. In such cases the clearance between the yarn and the mirror can be increased.

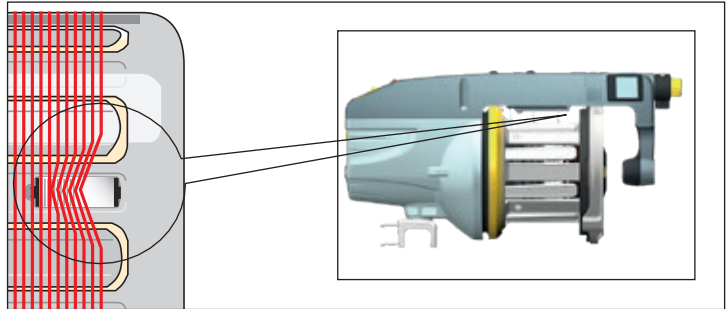

3. Adjust the clearance by rotating the mirror 180 degrees.

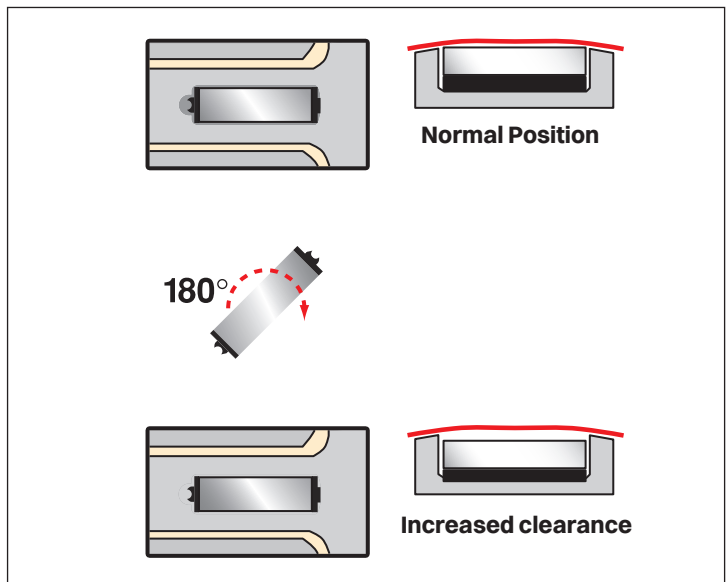

Mech. sensor

2. Certain yarns may cause excessive vibration of the sensors. This can be remedied by increasing the damper pressure.

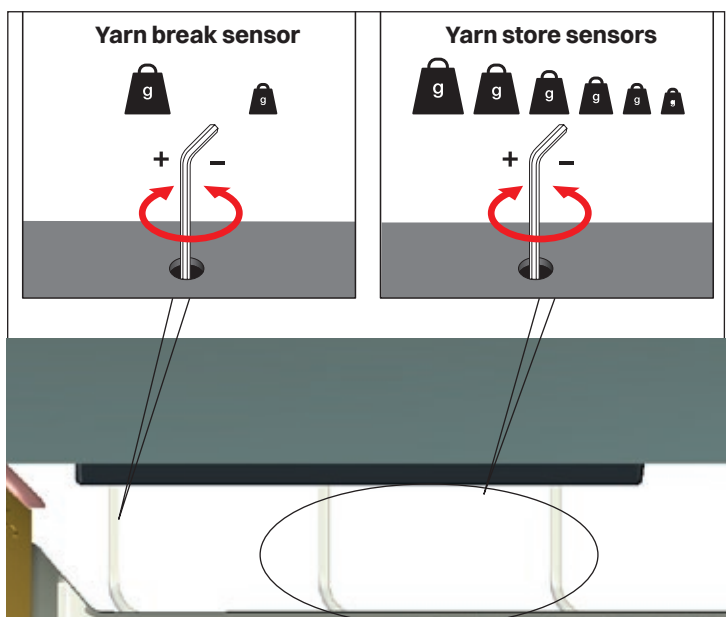

## Luna X4

The sensors are adjustable in three stages:

Level 1 - Very fine yarns

Level 2 - Normal setting

Level 3 - Very heavy yarns

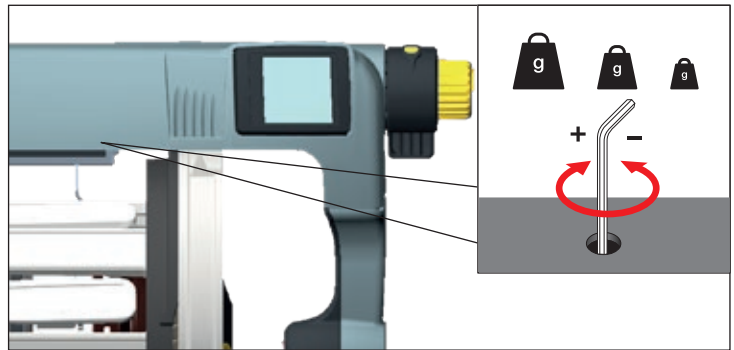

## HD X3

The mechanical sensors are placed on the fixed part of the spool body.

The sensor (1) controls MAX reserve level, and the sensor (2) controls MIN reserve level.

The force needed to press down the sensors is controlled by a spring, and it is adjustable with screw (3).

Turn the screw (3) anti-clockwise to increase the sensor strength, turn it clockwise to reduce it.

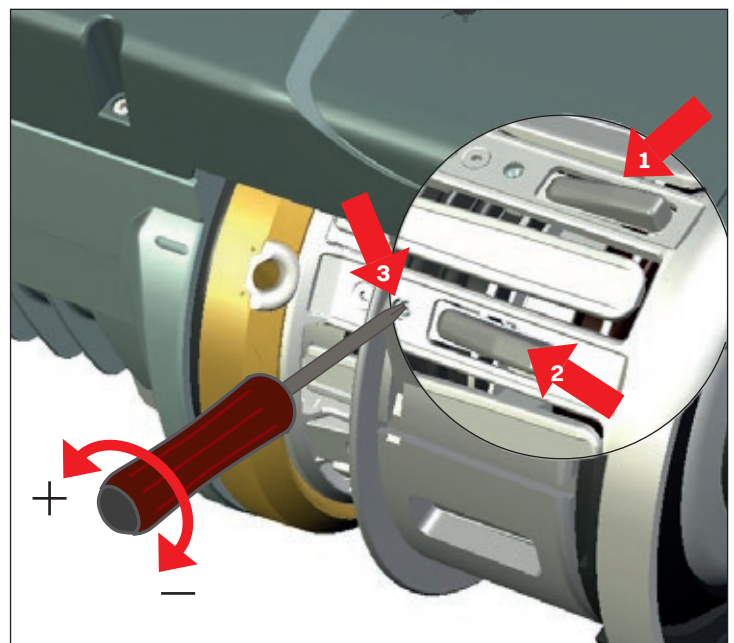

### AUTOMATIC CALIBRATION OF THE SENSORS

#### NOTE

Before starting the automatic sensors calibration, check the following:

- Remove all yarn from the feeder
  - The spool body must be in correct position.
  - The sensors must be free to correctly move up and down.
  - The sensors ring must be correctly fixed.
1. Switch OFF the feeder.
  2. Disable the TFE9 by moving the switch (4) upwards. The LED of TFE9 must be steady-ON in red color.(5)
  3. Switch ON the feeder and let it turn without weft for at least 50 revolutions, until the winding disk stops. (feeder red light steady ON).
  4. Switch OFF the feeder, and enable the TFE9 by moving the switch down
  5. Thread the yarn through the feeder (see page 25)
  6. Switch ON the feeder and load a new weft reserve.

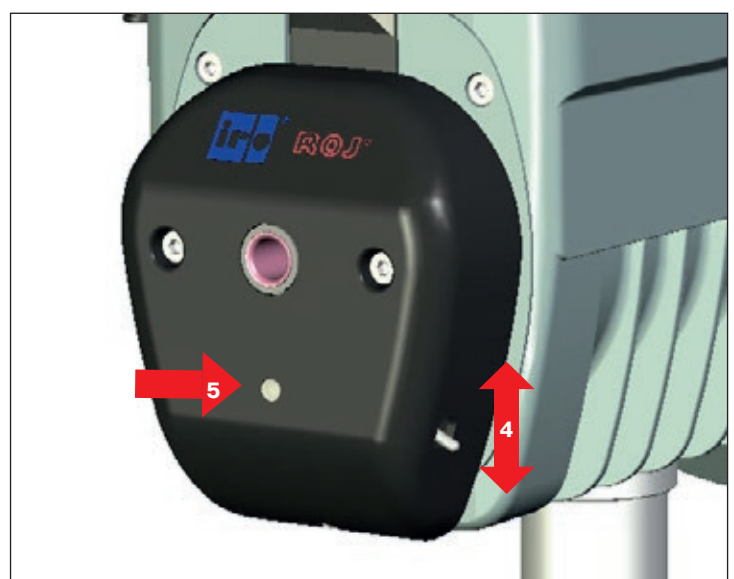

LED (5)

When disabled, the LED (5) is steady RED ON.

When enabled, the LED (4) is GREEN only when the yarn is creating signal, otherwise it is OFF.

**TENSION SETTINGS**

**BRUSH**

When using a brush it is possible to use the whole setting area of the brush holder ring.

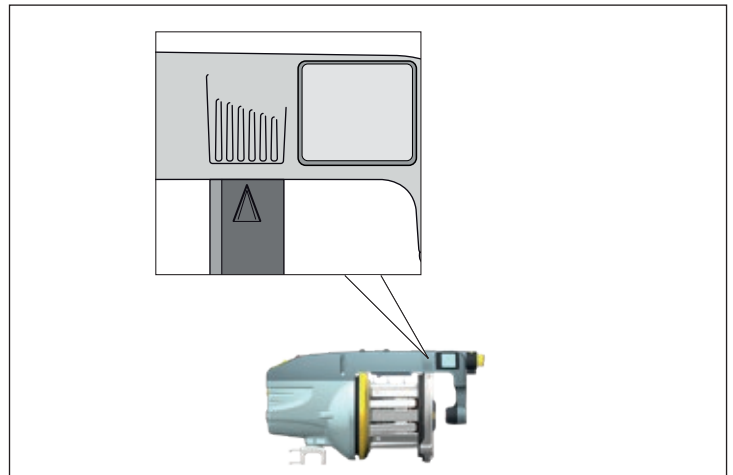

**FLEX**

When using a flex it is important to keep the settings in the center of the setting area, to ensure proper tension and longer life time of the flex. Avoid to set the brush ring in the outer areas.

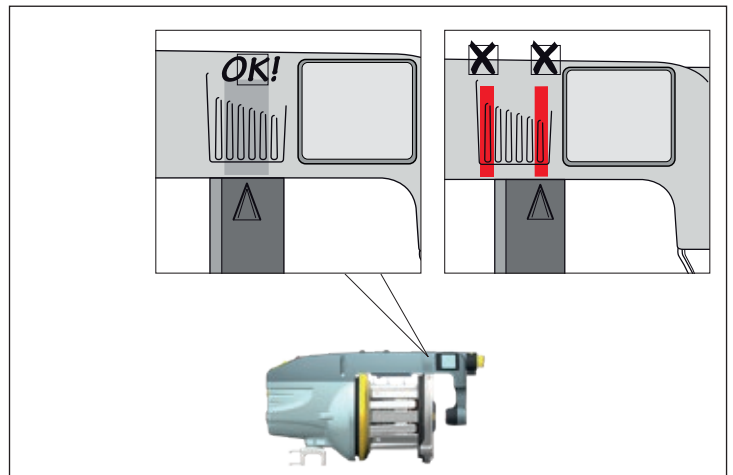

**BALLOON CONTROL**

Balloon control adjustment.

**NOTE**

**Excessive brush tension will cause abnormal wear.**

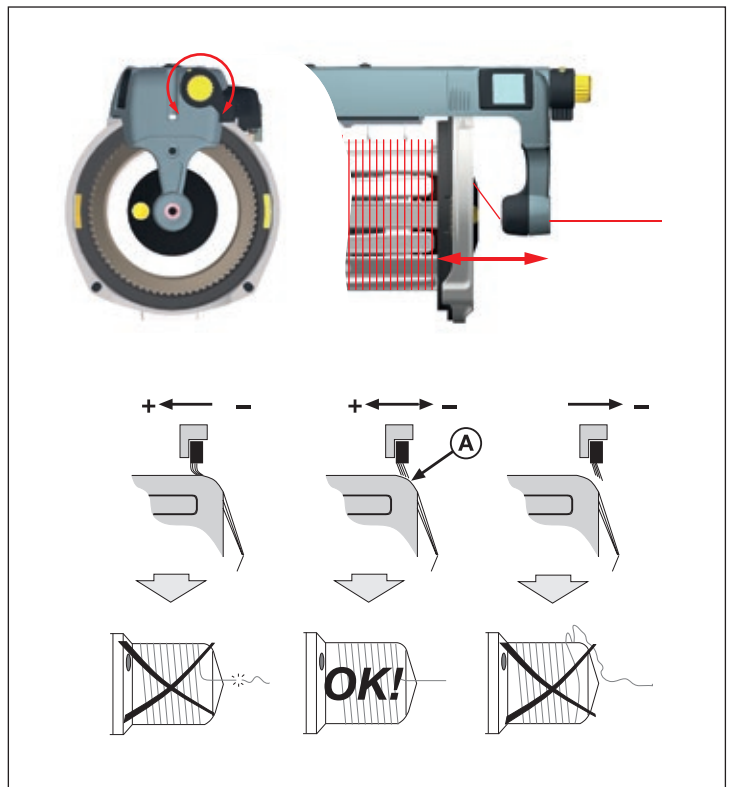

**XD X4, XD X3 Plus, HD X3**

Ramps are used when weaving with none elastic yarns that become too tightly wound around the spool body.

One, two or three ramps can be mounted.

Start with mounting one and if needed, mount additionally.

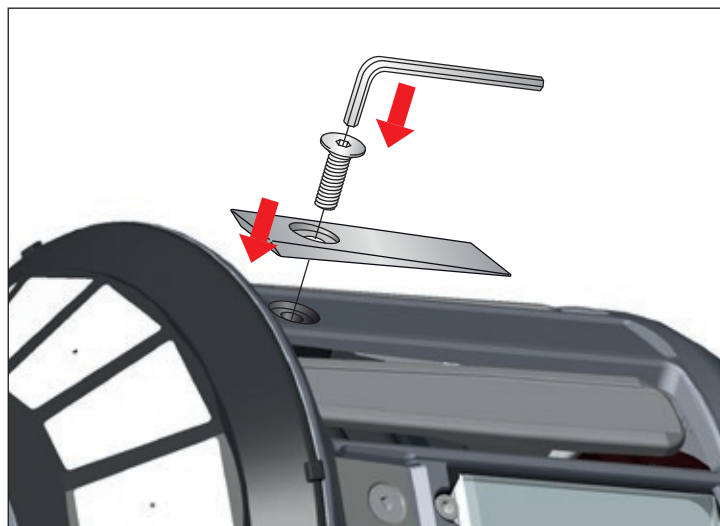
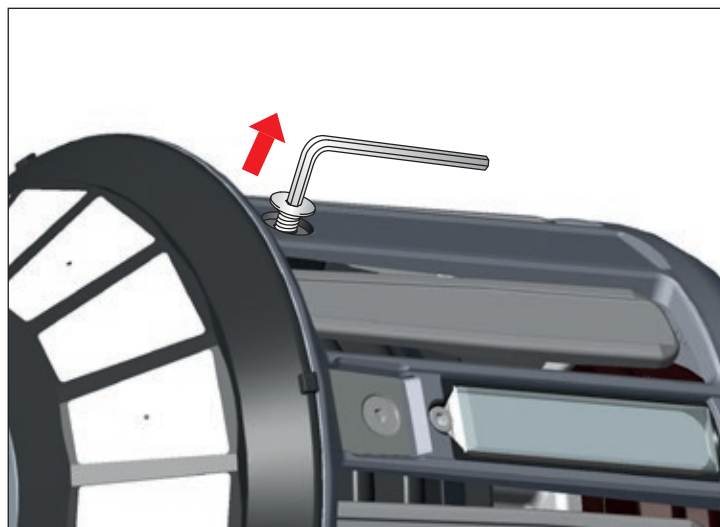

### BRUSH RING ALTERNATIVE

Z for Z-rotation  
S for S-rotation  
Straight for Z and S rotation

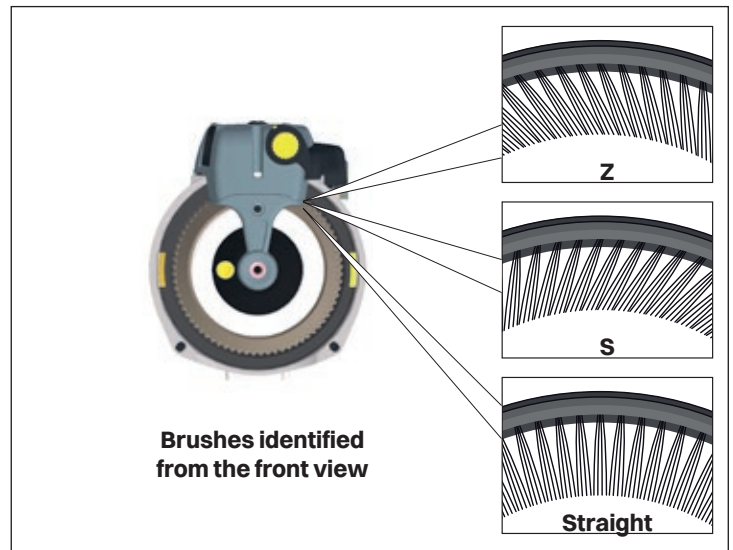

### BRUSH MOUNTING

Rotating the slide shift lever (1) will detach the brush holder (2) from the spool body.

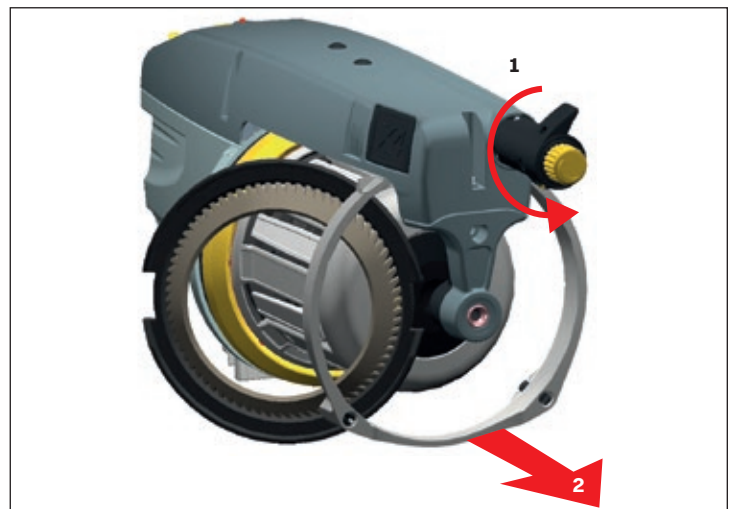

Ensure that the brush ring is correctly positioned (3) when attaching.

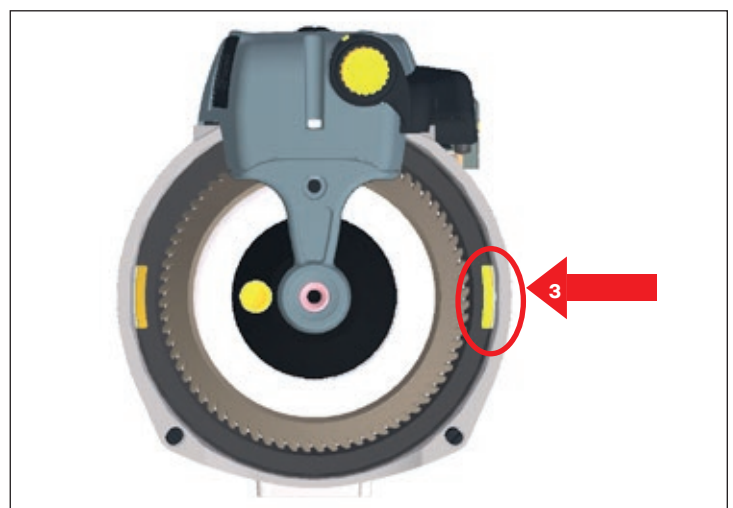

**MOUNTING**

Rotating the slide shift lever (1) will detach the brake (2) from the spool body.

**NOTE**

It is important to use a brake suited for the specific application to prevent reduced life time of the brake.



**NOSE OUTPUT: FLEX BRAKE**

Attach nose output depending on the mounted type of Flex brake to ensure function.

**NOTE**

The performance of a tensioner can be affected by various factors connected to the specific yarns being used. In case of uncertainty it is recommended to carry out a weft insertion test.

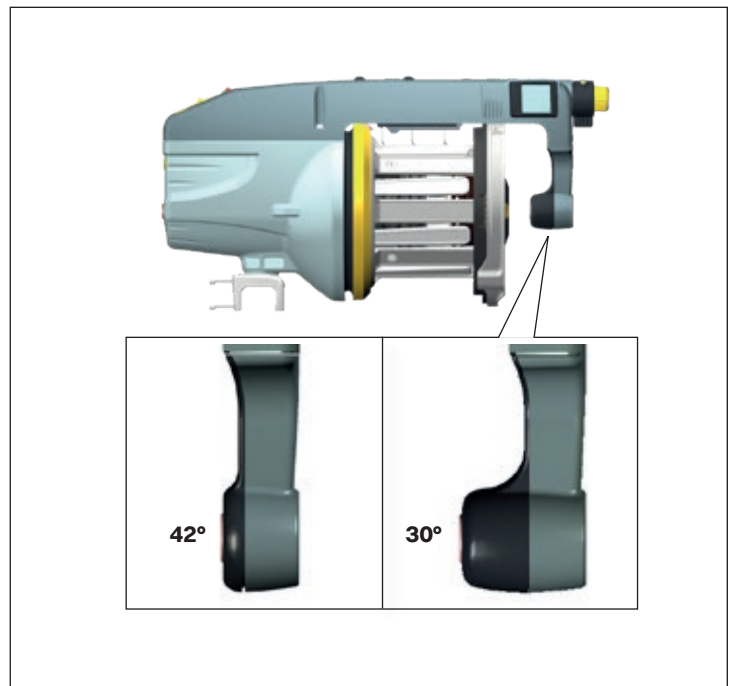

**NOSE OUTPUT: LAMELLA CAGE**

Using a Lamella cage requires a 42° nose output.

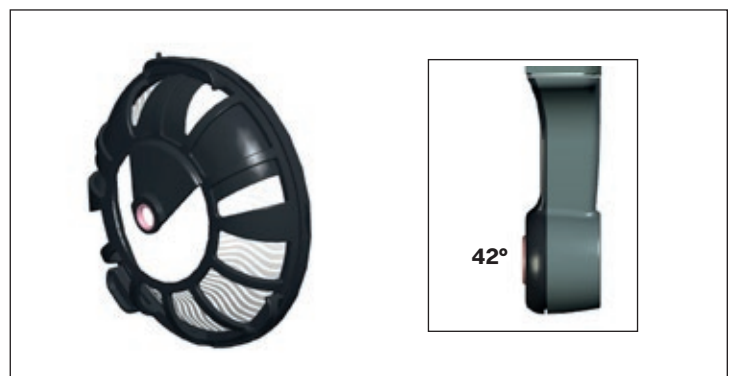

**BRUSH RING ALTERNATIVE**

Z for Z-rotation  
 S for S-rotation  
 Straight for Z and S rotation

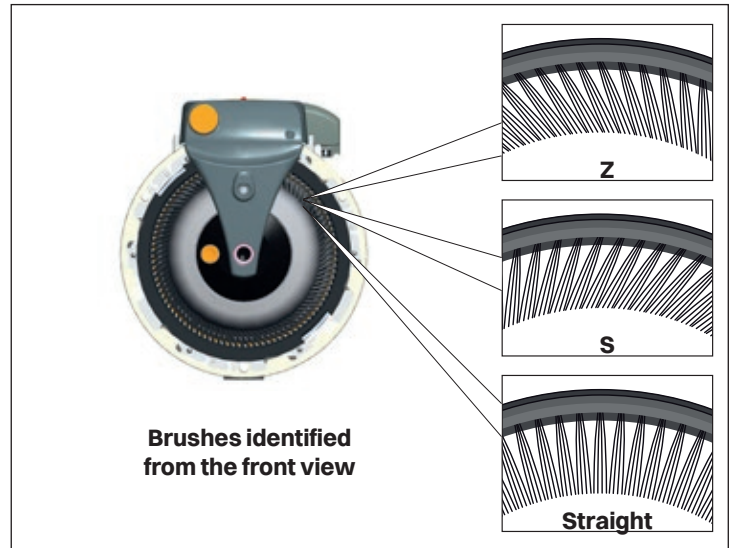

**MOUNTING**

Rotating the slide shift lever (1) will detach the brake from the spool body.

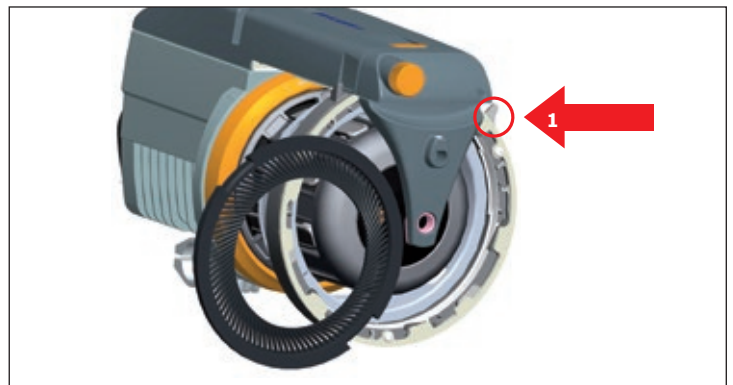

Ensure that the brush ring is correctly positioned (2) when attaching.

**NOTE**

It is important to use a brake suited for the specific application to prevent reduced life time of the brake.



**NOSE OUTPUT: FLEX BRAKE**

Attach nose output depending on the mounted type of Flex brake to ensure function.

**NOTE**

The performance of a tensioner can be affected by various factors connected to the specific yarns being used. In case of uncertainty it is recommended to carry out a weft insertion test.





Alternative for Chrono X4 and Luna X4

**RTC - RAPID TENSION CONTROL**

The Rapid Tension Control (RTC) is a fast reacting, programmable weft tensioner system, which adjusts to the optimal tension required for the complete weft insertion cycle.

By the use of an integrated electromagnet and a S-flex the system ensures the correct tension at all times.

The optimized braking cone ensures a solution with excellent performance, high resistance to wear and with the great advantage of being self-cleaning.

The system requires only setting of one device for the weft tension. The integrated panel is easily used for electrical opening and programmable settings.



**INSTALLATION ON WEAVING MACHINES**

Installation, when 26 VDC is supplied from weaving machines.

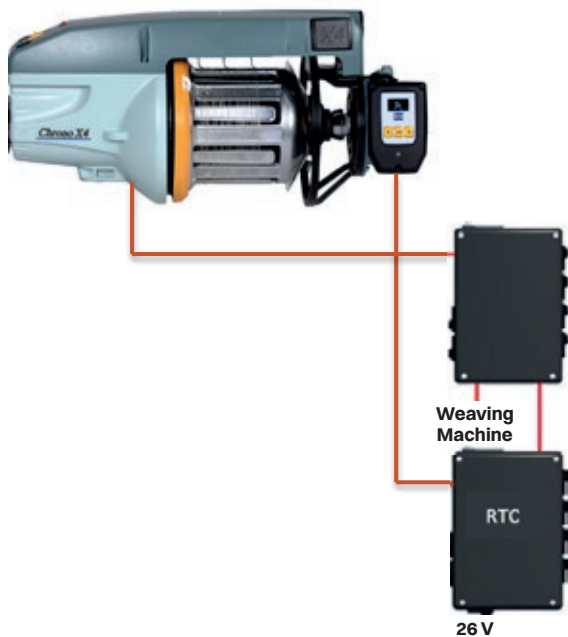

Installation for other weaving machines.

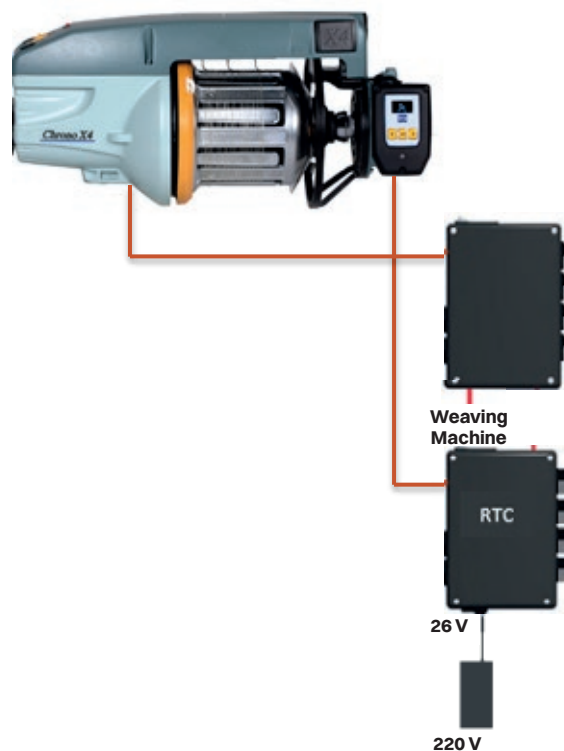

Alternative for Chrono X4 and Luna X4

**FUNCTIONS**

When power up the RTC the display shows the icon for electrical opening. Press the arrows to toggle between electrical opening and settings. Press enter to confirm.

**Electrical opening**

The brush holder remains open for 30 seconds then it automatically closes. Pressing enter again will immediately close the brake.

**Settings**

Possibility to set levels and angles to ensure correct tension.

**Static level**

Possibility to set static levels to manually check yarn tension before weaving.

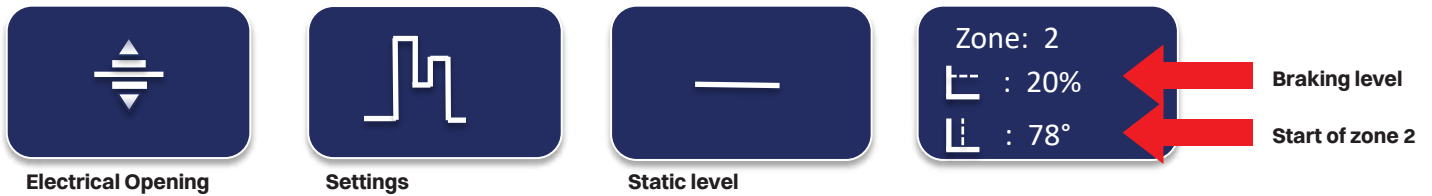
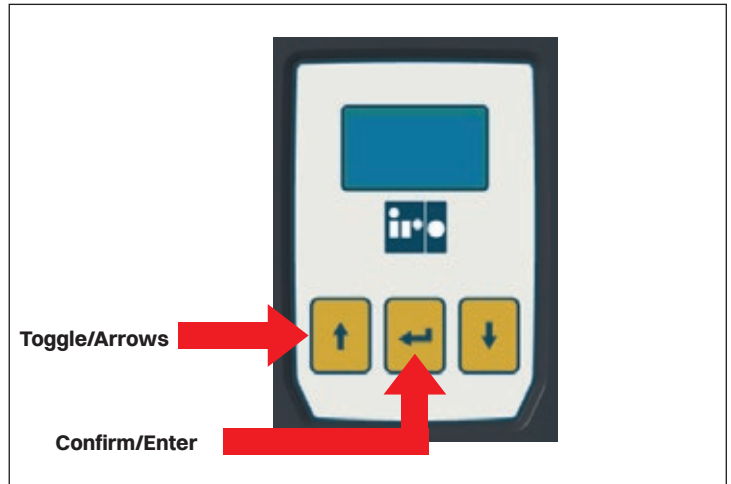

**ZONES AND ALLOWED SETTINGS**

Examples of settings

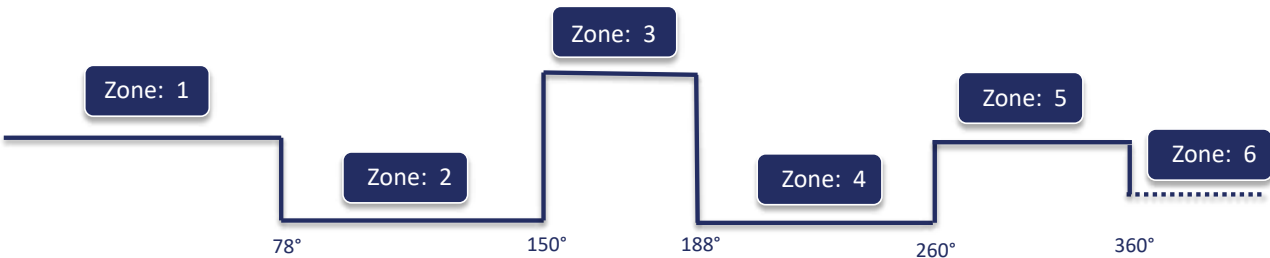

Zone: 1 ⏏ : 30%	Zone: 2 ⏏ : 20% ⏏ : 78°	Zone: 3 ⏏ : 40% ⏏ : 150°	Zone: 4 ⏏ : 20% ⏏ : 188°	Zone: 5 ⏏ : 30% ⏏ : 260°	Zone: 6 ⏏ : 23%
--------------------	-------------------------------	--------------------------------	--------------------------------	--------------------------------	--------------------

<b>Zone 1</b> Allowed settings: 0% - 100%	<b>Zone 2</b> Allowed settings: 0% - 100% 60° - 100°	<b>Zone 3</b> Allowed settings: 0% - 100% 130° - 165°	<b>Zone 4</b> Allowed settings: 0% - 100% 170° - 210°	<b>Zone 5</b> Allowed settings: 0% - 100% 235° - 310°	<b>Zone 6 Idle</b> Allowed settings: 0% - 23%
-------------------------------------------------	---------------------------------------------------------------	----------------------------------------------------------------	----------------------------------------------------------------	----------------------------------------------------------------	-----------------------------------------------------

## Alternative for Chrono X4 and Luna X4

## HOW TO SET ZONES

1. Use the **arrows** to mark the zone, level or angle to be changed.
2. Confirm by pressing **enter**. Only the value is now marked. Use the **arrows** to change the value. Press **enter** again to leave this mode
3. To go back to settings or electrical opening, use the arrow to mark the **"home arrow"** and confirm by pressing **enter**.

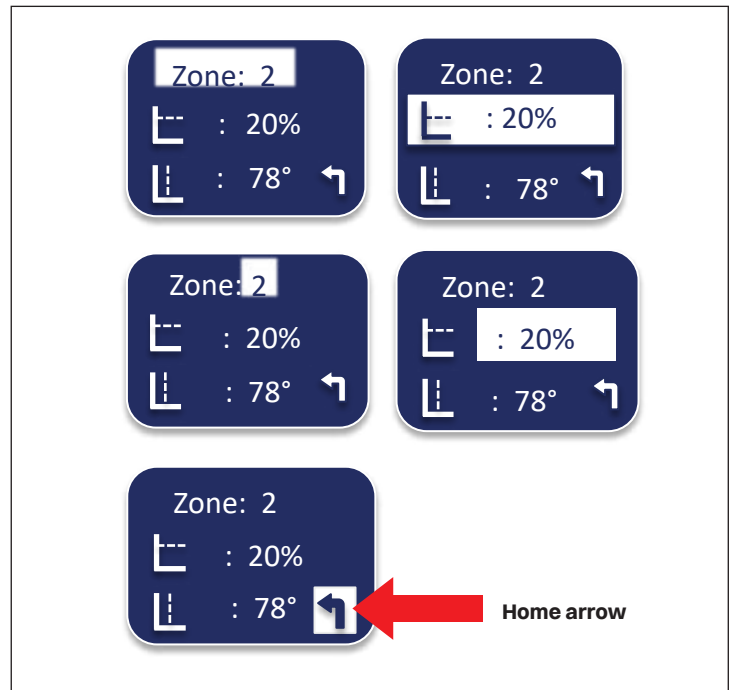

## 3.3 HOW TO USE STATIC LEVEL

1. Press **enter**. Only the value is now marked. Use the **arrows** to change the value.
2. Go to last row and press **enter**. Only OFF is now marked.

Toggle between **ON** and **OFF** with the **arrows**.  
The level is activated for 20 seconds.

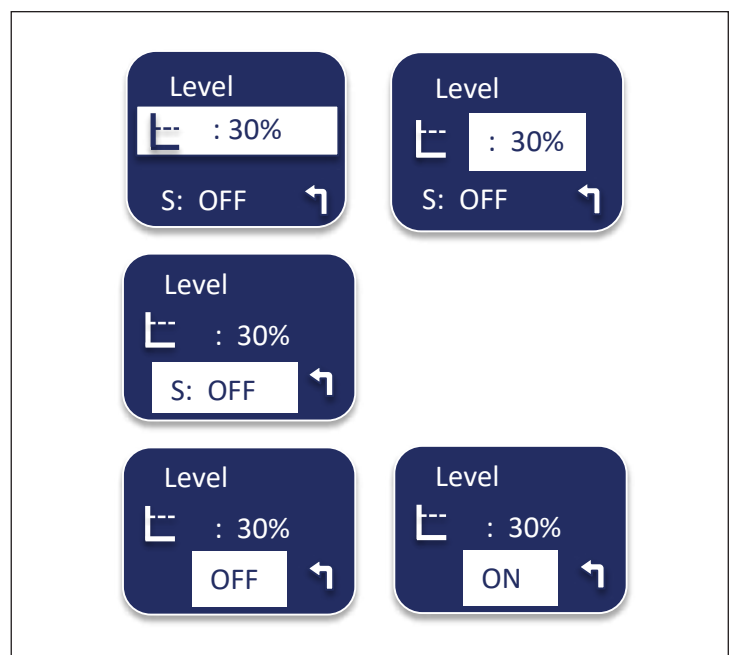

## THREADING

1. Open the brush holder with the function **Electrical opening**
2. Thread the yarn using a threading needle.



**REPLACE THE BRAKE ELEMENT**

1. Remove the top cover.
2. Remove the inner ring by pushing it in the plastic gaps.
3. Mount a new cone and snap the inner ring.

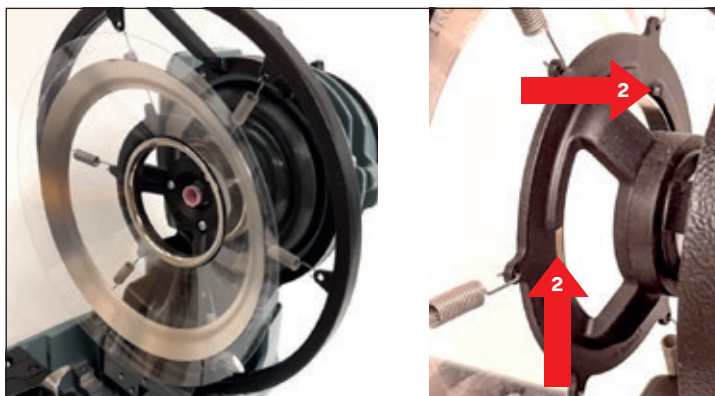

**RECOMMENDATIONS**

Zones:

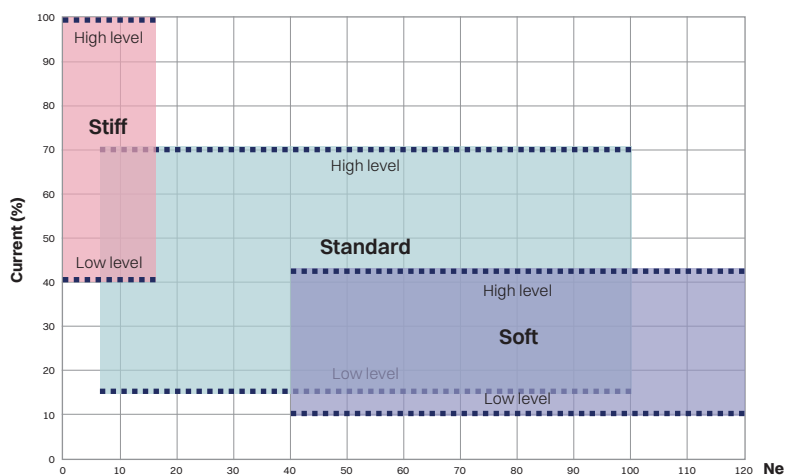
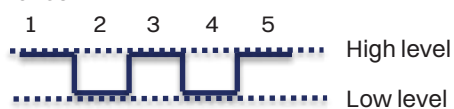

### THREADING THE TEC

- Open the cover (1)
- Insert a threading needle (2)
- Pull on the yarn (3). The yarn will wrap itself around the needle
- Pull out the needle (4)
- Close the cover (5)

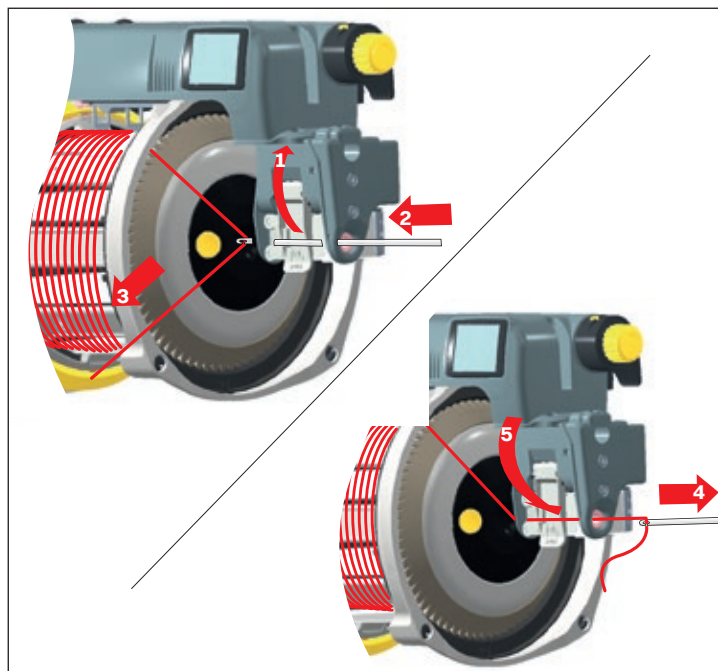

### Position A

Using the TEC together with a 30° FlexBrake.

### Position B

Using the TEC together with a 42° Flexbrake or Lamella cage.

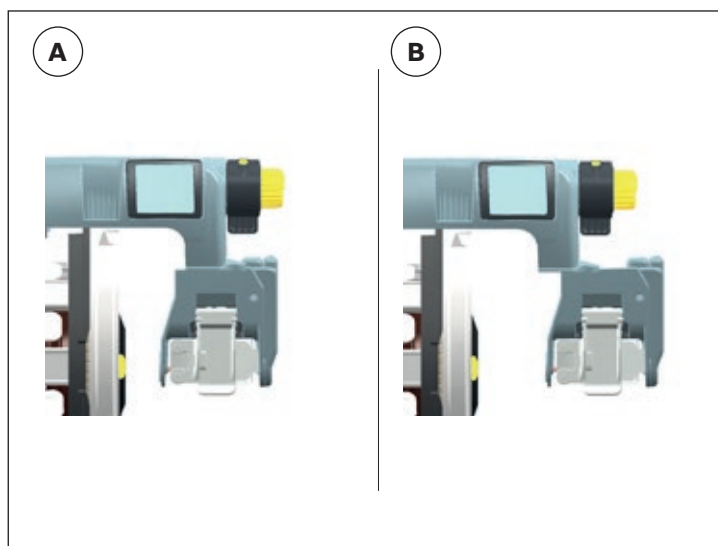

### CHANGING THE TENSION STRIP

- Open the cover (1)
- Remove the cap (6)
- Tilt the strip to remove (7)
- Tilt the new strip forwards to insert
- Close the cover (5)

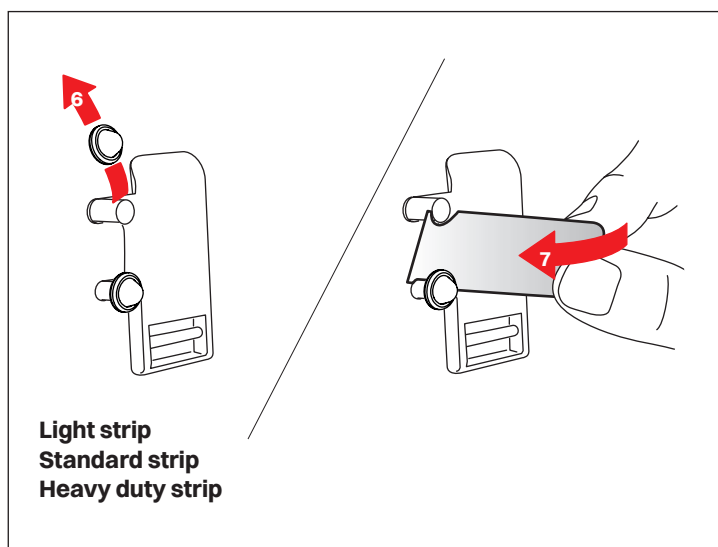

**INPUT TENSION**

Control input yarn tension to the CAT.

**NOTE**

The brush ring should only be used for balloon control.

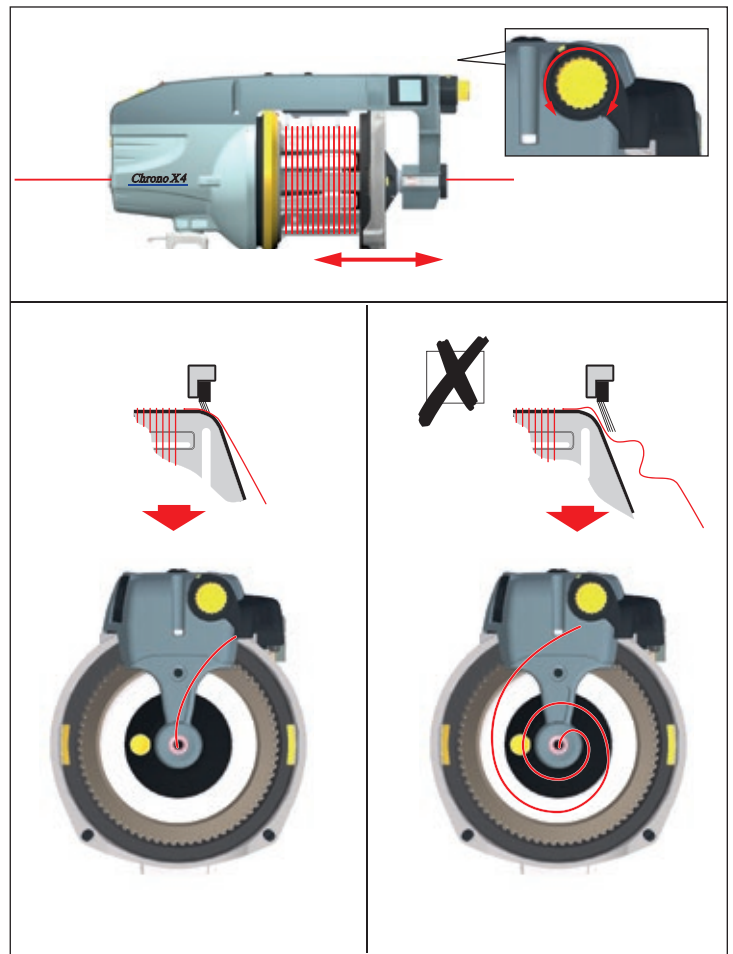

**OUTPUT TENSION**

Adjustment of the output tension.

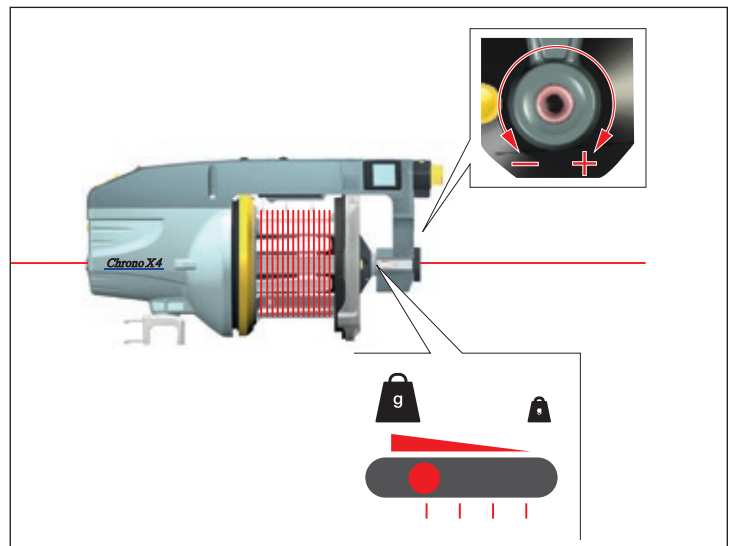

Balloon control adjustment.

**NOTE**

Excessive brush tension will cause abnormal wear.

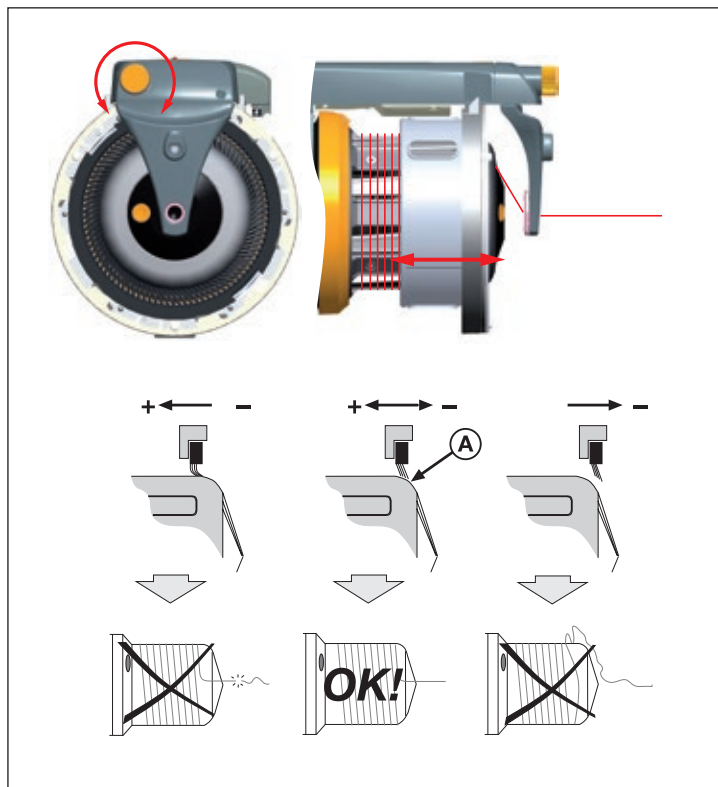

**NOSE POSITION**

Mounting position of the nose: 30° or 42°

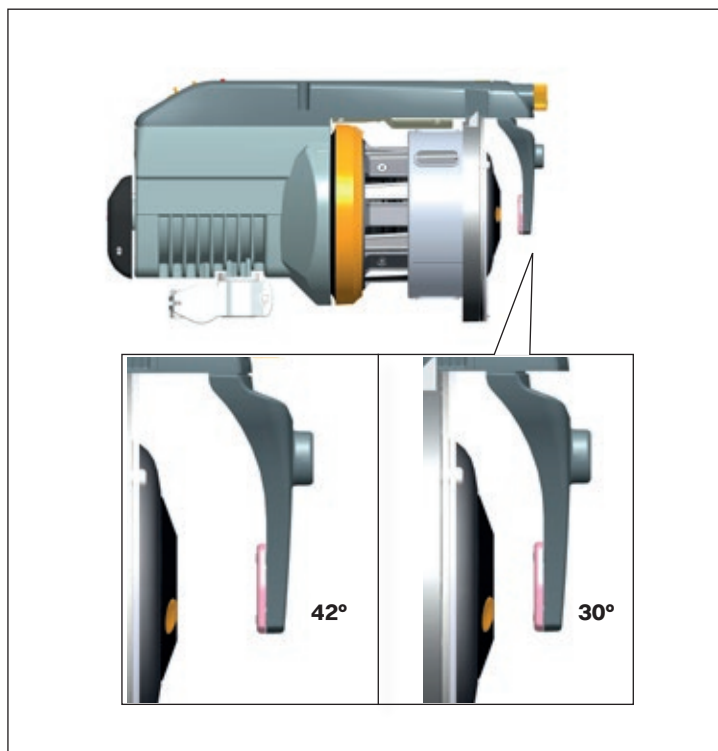

## Alternative for HD X3

Suitable for heavy yarns which create large balloons.  
Suggested for polypropylene flat tape on projectile looms.

**NOTE**

**There is no braking function on the yarn when the funnel is installed since it is used only to control the balloon effect during the yarn taking-off.**

Remove the brush holder by pressing the button (1) on the top.

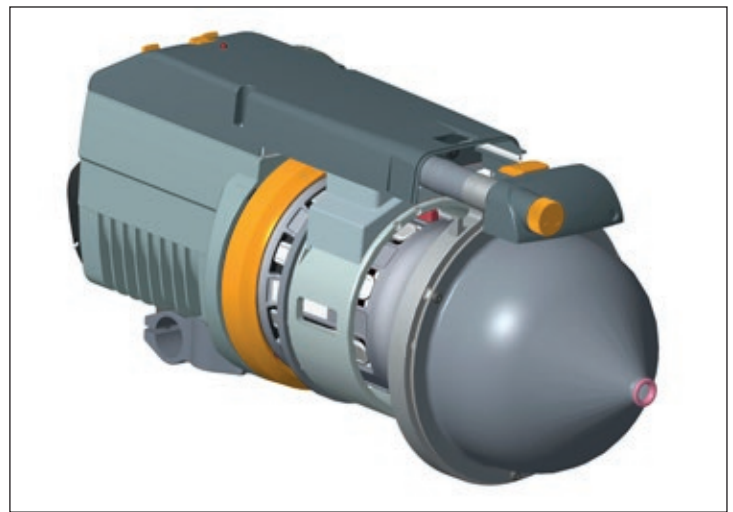
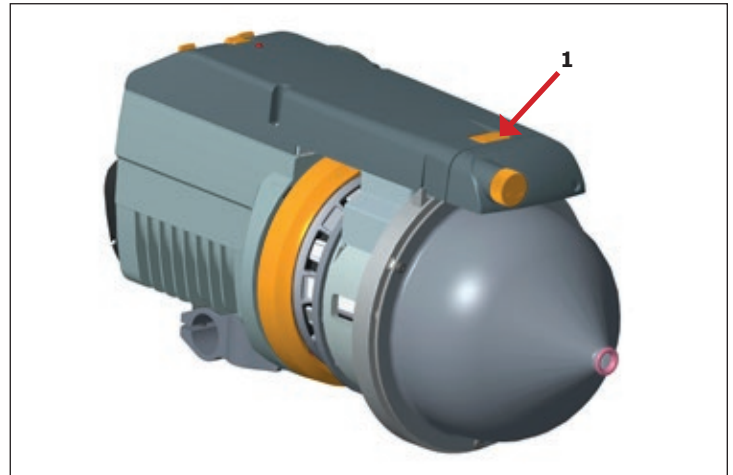
**FUNNEL SCREWS**

The cone is kept in place by the three funnel screws (2).  
The funnel screws are thread locked (loctite) and tightened to recommended torque (3Nm).

**NOTE**

**If the funnel screws are unscrewed or loose, be sure to add new thread locking (loctite) and tighten screws to recommended torque (3Nm).**

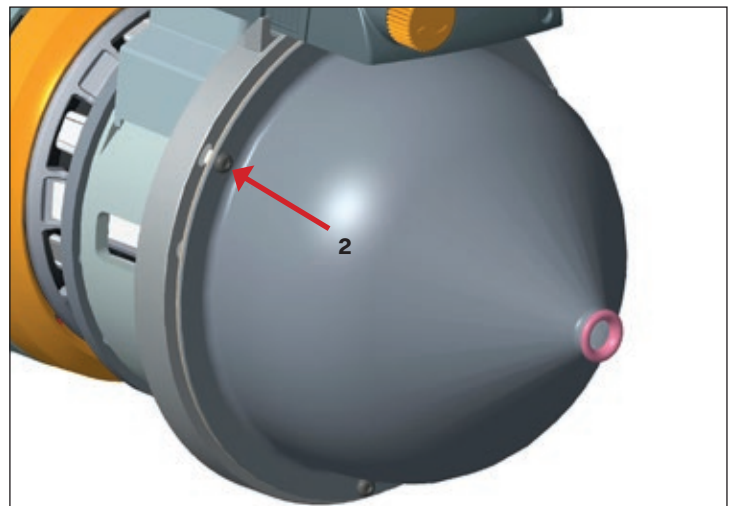



**Luna X4, Chrono X4, XD X4**

**BUILT-IN HMI-PANEL**

The Built-in HMI panel on Luna X4, Chrono X4 and XD X4 will show information, settings and warnings when using the accessories TED and ATC.

**NOTE**

**The CPU is able to detect if TED or ATC are connected, and will change the info in the display.**



**GENERAL FEEDER INFORMATION**

The knob with a push button is used to interact when equipped with ATC. If equipped with TED use the push button. User can accede to specific section, pushing 3 time the push button within one second.



Feeder info section is structured of a list of pages (with different parameters), that can be scrolled via the push button.

Parameters are basically read only, user cannot modify them (TED has a simple 1-button interface). At each click, the following page is displayed, until come back to the home page.

1. Feeder software version
  - Application
  - Custom boot
2. Feeder Hardware version
  - CPU PCB HW revision
  - CPU PCB HW Serial number
  - CPU PCB type
  - ATC/TED PCB HW revision
3. Dip switch status
4. Loom protocol and Feeder adress number

In case of alarm is active, the alarm info is displayed before be back to the home page.

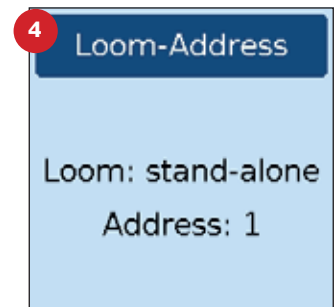
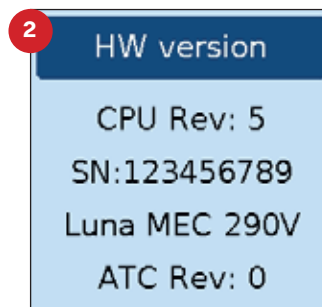
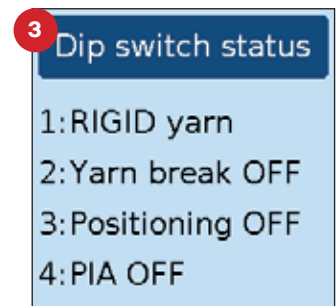
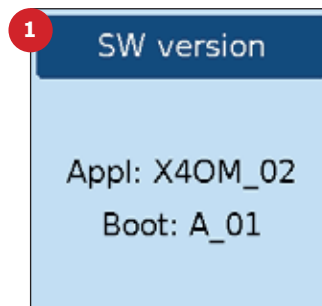

## Luna X4, Chrono X4, XD X4

### ALARMS MENU

In case of a feeder alarm, display shows the information of the kind of alarm. Once the alarm is automatically reset, or thanks to the user operation on the feeder, display is back to home page.

As described above, user can force the visualization of ATC home page, even in presence of an active alarm, just pushing the ATC knob button or the TED button.

In this case, the icon  in the home page informs the user about the feeder alarm status.

It's then possible control again the alarm kind, in different way between TED (using 1-click interface) and ATC (using knob and button through the menu). Anyway, alarm page format is the same.

The visualization of a new alarm is disable if the menu is open, in order to allow the user to handle the settings even if the feeder is in error state.

However, the new alarm will be displayed before the operator is back to the home page.

### NOTE

**For the complete alarm list see the separate documentation.**

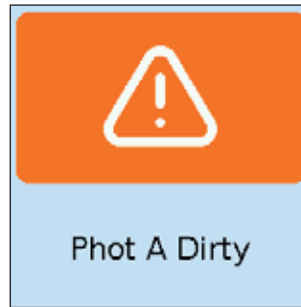

Warnings are shown with orange graphics.



Heavy and Fatal Errors are shown with red graphics.

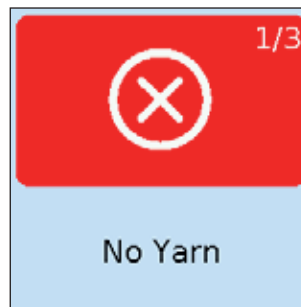

In case of multiple alarms, the user is advised with the number of active alarms. 

In case of TED, only the last alarm is displayed, with ATC it is possible to scroll the alarm list with knob.

**TED – TENSION DISPLAY**

TED (Tension Display) makes it possible to reproduce weft tension settings from one machine to another enabling a fast start up the next time the same article is woven.

TED displays the element position of the brake ring holder in relation to a set zero position.

The zero position is the point where the break element of the used tensioner (preferably S-flex) touches the surface of the feeder spoolbody.



**HOME PAGE**

Turn the S-flex holder adjustment knob clockwise to increase the tension.

The new position, highlighted in the dark blue area, is automatically displayed by the TED device.

By turning the S-flex holder adjustment knob counter-clockwise the tension is decreased.

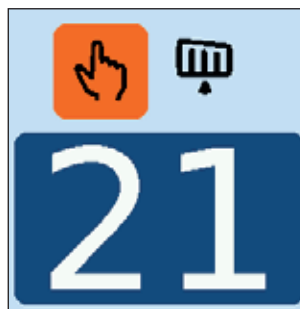

**SETTING THE ZERO ELEMENT POSITION**

The zero position needs to be set manually when a new S-flex is installed.

Install the S-flex and adjust the position of the S-flex holder by turning the adjustment knob until the S-flex brake element touches the front part of the spool-body.

- Press the TED push button for a couple of seconds, until the display shows “0?”.
- Confirm the zero setting using the push button within four second.
- If the zero setting has been confirmed correctly pushing the button within the four second timeout, the TED display now shows a value of “0” to confirm that the device is set to the zero position. Otherwise, the TED concludes the zero setting mode and return to displaying the previous current position (“xx”).



**NOTE**

**Zero element calibration is not allowed in case of loom running.**

**ELEMENT POSITION STROKE**

Element position is two digits format.

- Range from “1” to “80”, usual working position.
- Value “0”, where the S-flex brake starts to touch the spoolbody surface and there is basically no tension added by the brake. It’s the zero element calibration position.
- Negative range “-1” to “-9”, where S-flex does not touch the spoolbody.



- Out of normal range:  
 “++” in case the position is higher than 80;  
 “--” in case the position is less than -9



**NOTE**

**In case of out-of-range setting, MIN and MAX icons advise the user.**

**ALARMS**

In case of a feeder alarm, display show the information of the kind of alarm.

Once the alarm is automatically reset, or thanks to the user operation on the feeder, display is back to home page. However, user can force the visualization of TED home page, even in presence of an active alarm, just pushing the TED push button.



In this case, the icon  informs the user about the feeder alarm status, until the alarm is removed.

**NOTE**

**See the section “HMI Panel” for additional information.**

**FEEDER INFO**

Thanks to the display, feeder can show some information about itself, not referred to TED and ATC.

**NOTE**

**See the section “HMI Panel” for additional information.**

**ATC – ACTIVE TENSION CONTROL**

The function of ATC-W is to automatically maintain consistent yarn tension at a pre-determined level unaffected by variable external factors such as bobbin size or yarn quality.

The required tension is easily set and monitored on the ATC display. Once set, the system constantly regulates itself ensuring consistent yarn tension during the weaving process.



**HOME PAGE**

A knob with a push button is used to interact with the ATC.

Home page consists of 2 areas, grouped in dark blue box (top of the screen) and light blue box (bottom).

In the dark blue area, different parameters are shown depending on the operation mode.

- Manual (MAN) mode.
- Automatic (AUTO) mode.
- OFF mode.

Acting on the knob, it is possible to increase or decrease the parameters, always highlighted on dark background:

- in Manual mode, the brake holder position
- in Automatic mode, the reference tension

In the light blue area, it is always shown the actual tension measured, parameter handled only by the application (not by the user).

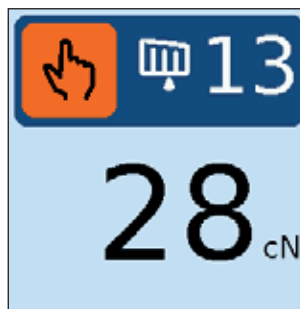

Manual (MAN) mode.  
Orange icon, with brake holder position in number of steps

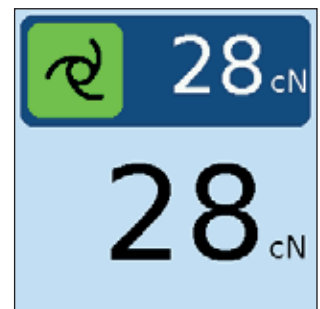

Automatic (AUTO) mode.  
Green icon, with target or reference tension ATC has to maintain.

**OCB [OPEN/CLOSE BRAKE] BUTTON**

The additional OCB [Open/Close Brake] push button on the top of the motor module, allows the “quick release” function, fully opening the brake ring holder by the motor driving.

Display shows this particular states, with specific icons: a warning to pay attention during the opening, and the open state once reached the end of the stroke.

If the user push again the OCB button, one short click, the brake is closed, even if it is opening (it is stop and following closed). When the brake is again at its original position, previous screen (home page) is shown again.

OCB in open status prevents loom to start.

OCB function is not always enabled, but only

- in case of loom stopped (CAN);
- or if the feeder is switched off or in standby, even if the loom is running.

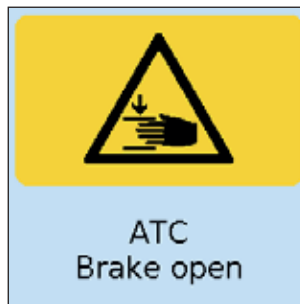

ATC  
Brake open

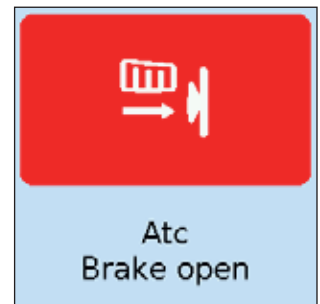

Atc  
Brake open

**HMI MENU NAVIGATION AND PREVIEW**

Pushing the knob button, display lefts the home page to enter in the first level of the menu.

Usually, settings in the menu are seldom used, for configuration only or service purpose.

In order to enter to the following level or validated the value, the user acts on the knob button. To scroll the menu or change the value, the user acts on the knob.

Inside a menu or sub-menu, keeping pressed the knob push button for 3 seconds, the menu is closed and the home page shown directly.

Parameters can be changed through the knob and confirmed with the push button (short press). If a parameter is changed but not confirmed, it is possible to reload the previous value, keeping the push button pressed for 3 seconds.

Table shows the structure of the HMI:

<b>Home page</b>			<b>Lvl</b>
<b>Settings</b>			
Brake control mode	MANUAL/ AUTOMATIC / OFF		
Keylock	ON (default) / OFF / PASSWORD		
Unit of measure	cN (default), AUTO		
Max Adjustment	OFF (default) / WIDE / MEDIUM / LIMITED		<b>2</b>
Sensitivity	Slow / Normal (default) / Fast		<b>2</b>
<b>Service Setup</b>			
Zero holder	CANCEL / START	For ATC-W installation	<b>2</b>
Sensor off-set	CANCEL / START / STATUS	For ATC-W installation	<b>2</b>
<b>Password</b>			
Enter password	X X X X X Standard mode Lvl1 Enhanced mode Lvl2		
(Key-unlock password)	X X X X X	1 1 1 1 1	*
<b>Alarm Menu (see specific section)</b>			
<b>Info Menu (see specific section)</b>			

Levels [Lvl] means the level required to access to the parameter according the password entered (see paragraph Password).

\* Enter in this page only from home page in case of keylock password active

**SETTINGS**

Enter the settings menu using the knob with a push button.

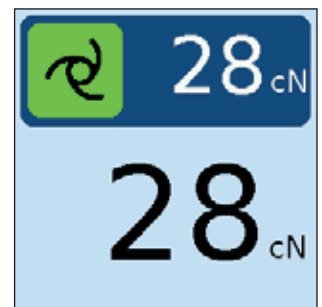
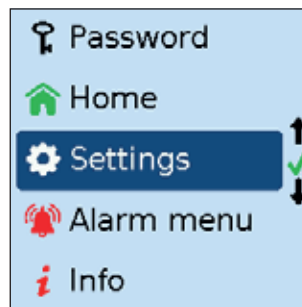

**SETTINGS - BRAKE CONTROL MODE**

In menu Brake control mode it is possible to move from Automatic to Manual mode.

Since this command is the most used, is it possible to speed up the swap from MAN to AUTO and vice versa directly from the HOME PAGE keeping the button hold for 3 seconds.

In this way, the main functions the operator will use, such as move from auto to manual, move the brake holder in manual mode, move the reference in auto mode, are made directly without enter the menu.

It is also possible to disable the sensor in OFF mode.

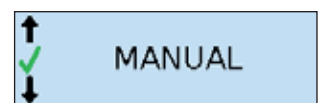
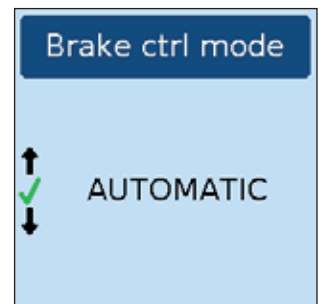
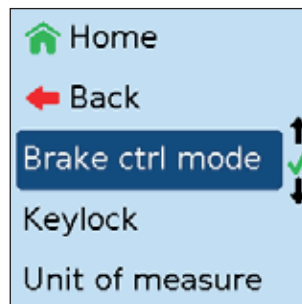

**SETTINGS - BRAKE CONTROL - MANUAL MODE**

In MANUAL mode the brake element position is adjusted with the knob. 1 click of the knob equals 1 step position increase or decrease, depending on the rotation direction.

Element position is two digits format, like described for TED.

- Range from “1” to “80”, usual working position.
- Value “0”, where the S-flex brake starts to touch the spoolbody surface and there is basically no tension added by the brake.
- Negative range “- 1” to “-9”, where S-flex does not touch the spoolbody.
- Out of normal range:  
 “++” in case the position is higher than 80;  
 “- -” in case the position is less than -9

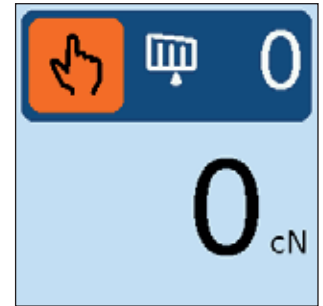
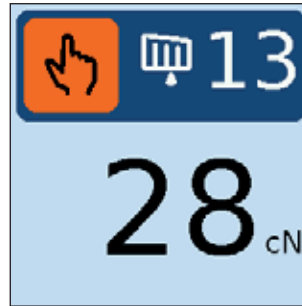

It is not required to apply a Zero Element calibration, during the ATC-W installation, because default values is store inside the device. See specific section.

In MANUAL mode, when the loom is stop, tension displayed is the actual tension the sensor is measuring, with an appropriate filtering. This can allow the operator to adjust the brake holder position pulling the yarn by hand and understand if the sensor is working correctly.

When the loom is running tension displayed is the average tension the sensor is measuring. This value becomes the reference when swapped in AUTO mode.

**SETTINGS - BRAKE CONTROL - AUTOMATIC MODE**

In AUTOMATIC mode the reference tension value, in the dark blue sector, is adjusted with the knob.

1 click of the knob equals 1 step tension (1 cN or 0.5cN depending on unit of measure) increase or decrease, depending the rotation direction.

In the light blue sector, tension displayed is the actual tension the sensor is measuring, with an appropriate filtering, depending on Sensitivity set.

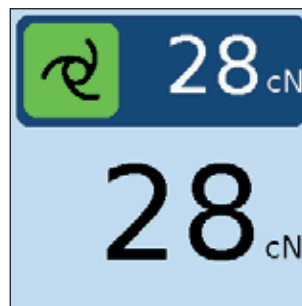

When the loom is stop, tension displayed is the last evaluated before the loom had been stop.

The minimum reference value settable is 3cN.

In OFF mode the tension is neither measured, nor displayed. The brake holder position can be adjusted like in MANUAL mode. This function can be used to exclude the ATC-W sensor in case not used, without disassemble the device.

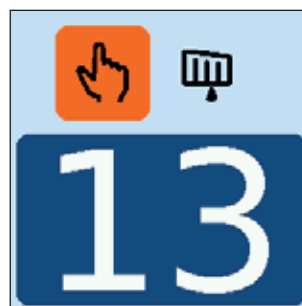

The HMI of ATC OFF looks like the TED, because in this configuration basically the device behaves like a TED, but motorized.

**SETTINGS – KEY LOCK**

In Keylock menu is it possible to lock the access to the ATC handling.

**OFF.** No key lock. As explained, the user is free to handle the knob and adjust parameters from the home page. If the user accidentally touch the knob, depending on MAN or AUTO mode, the brake holder position or the reference tension could be unintentionally adjusted.

**Key lock ON.** After a 30 seconds timeout without interaction, the knob is disabled. The user has to push the button to unlock ATC.

**NOTE**

**The OCB button is not subjected to key-lock function.**

**Key lock with PASSWORD.** Similar to previous, but under password. In order to unlock ATC-W it is necessary to add the password 11111. This feature is required by customer that want to avoid their workers can adjust the ATC.

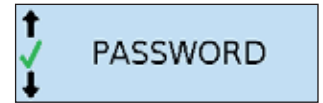
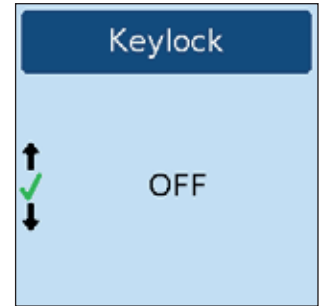
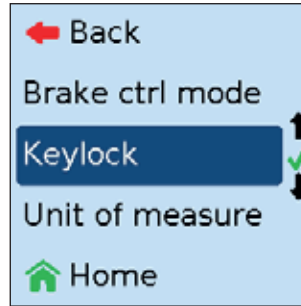

When ATC-W is locked the key symbol  is displayed in the home page.

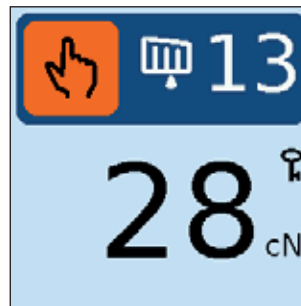

**SETTINGS – UNIT OF MEASURE**

Unit of measure is referred to the tension displayed, which can be “cN” or “AUTO”.

**cN** is the default value

**In AUTO** the unit of measure is automatically adjusted with a decimal digit XX.x in case of low tension.

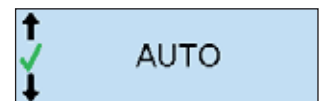
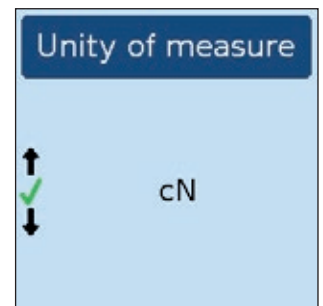
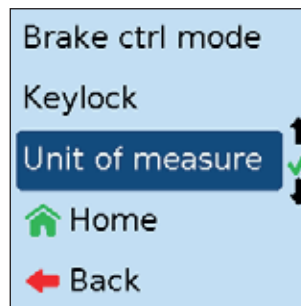

When the ATC-W is in AUTO mode, the uses can adjust the Reference tension is step of 0.5 mN.

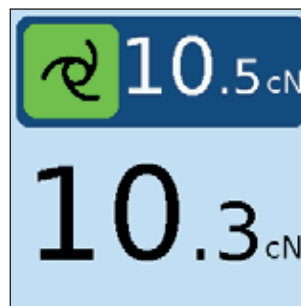



**SETTINGS – MAX ADJUSTMENT**

Max adjustment parameter allows to limit, in AUTO mode, the brake holder correction.

With Max adjustment set to OFF, there is no limitation.

With a different value, WIDE, MEDIUM or LIMITED, the brake holder adjustment is limited to a certain number of steps.

For example, setting Max adjustment = LIMITED, if the brake holder position was 20 when at the switch over between MAN and AUT, the maximum correction allowed to the motor control is inside a pre-defined restricted range.

This function can be set only after the access in “enhanced mode”. See section “Password” for more details.

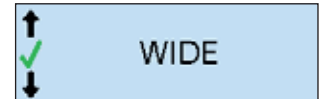
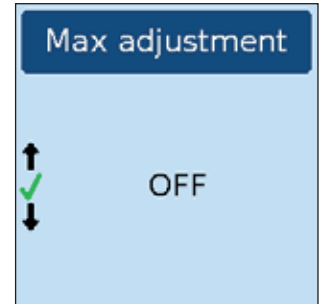
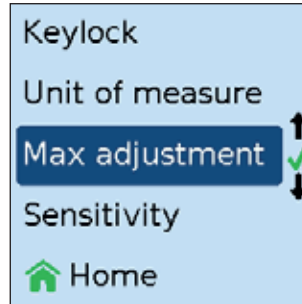

In AUTO MODE, Sensitivity allows to change the tension adjustment control, according three prefixed configurations:

- SLOW
- NORMAL (default value)
- FAST

This function can be set only after the access in “enhanced mode”. See section “Password” for more details.

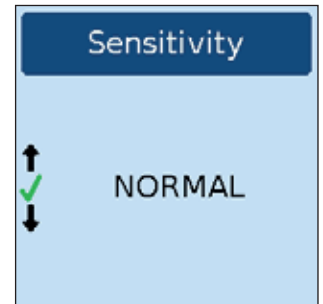
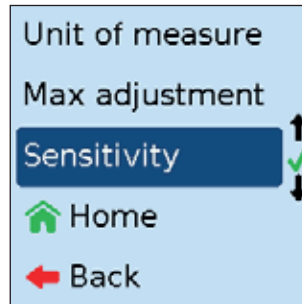

**ALARMS**

In case of a feeder alarm, display show the information of the kind of alarm.

Once the alarm is automatically reset, or thanks to the user operation on the feeder, display is back to home page.

However, user can force the visualization of ATC home page, even in presence of an active alarm, just pushing the ATC knob push button.

In this case, the icon  informs the user about the feeder alarm status, until the alarm is removed.



In general, in case of alarm is active, the alarm info is displayed before be back from the menu to the home page. See the section HMI Panel/Alarms” for additional information.

Below the table of the currently implemented alarms related only to ATC (or can influence ATC behaviour).

**NOTE**

**For any kind of alarm, the feeder stops the loom or not according the weaving machine protocol.**

Error	Description
Atc brake open	OCB function, when brake holder open
Tension meter failure	In case of the following conditions - Tensionmeter out of calibration or broken - Tensionmeter not plugged - Offset calibration failure ATC-W stops to work. Button resets the alarm.
Atc Yarn missing	Yarn is outside the sensor guide. ATC-W stops to work. Button resets the alarm.
Yarn tension error (Tension out of range)	If the reference tension is not reached within a certain number of picks, with a certain tolerance. Alarm is reset automatically at every loom start in case the tension error is in tolerance. In MANUAL mode the motor can be driven.
ATC out of Max Adjust	Max adjustment brake position reached, the brake cannot move outside of the min-max position range.
ATC motor failure	A motor lock event occurs during the motor driving.  ATC stops to work and motor is stopped. Button resets the alarm.
ATC Button error	Error in detecting the button at the power on. If active, TED and ATC are not recognised and so not handled.
Loom parameter missing	Missing parameters from the loom. ATC stops to work. Pushing the button, the alarm is not reset. The control is disabled in AUTO mode. Anyway it is possible to handle the ATC in manual mode. Error is still present in Alarm menu.
Anglebus Error (Zero pulse and sync pulse)	Angle bus from Loom is missing

**FEEDER INFO**

Info sub-menu where it is possible to read out feeder information.

This section is structured in different pages (with different parameters), that can be selected in the menu list.

Parameters are basically read only, user cannot modify them.

**NOTE**

See the section “HMI Panel” for additional information.

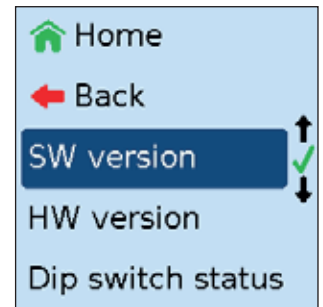
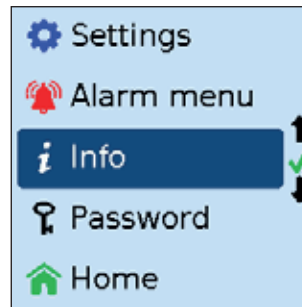

**INSTALLATION GUIDE**

Feeder is provided to end user with the motor module already installed in the top cover.

**NOTE**

**It is possible to modify the feeder configuration, changing ATC, TED and QR, but this operation must be done by expert people. This operation is not reported in this document.**

In any case, before use the ATC, perform the following installation steps.

1. Switch off the feeder and the loom power supply.
2. Assemble the ATC sensor to the feeder and fix it through the screw above.  
It is mandatory to use the included Bar 40.0070.010 and Compensating tensioner 40.0500.004.  
In case of special application, contact IRO/ROJ service.
3. Connect the ATC sensor cable to the output accessory connector in the feeder top cover.
4. Fix the cable conduit with the two screws.
5. Instal the feeder on the creel, in the exact position intended to use it in the weaving machine.
6. Switch on the power supply.
7. Accede to the Password menu and enter the "Enhanced level", which allows the installation operations.  
Ask the password to IRO/ROJ service.
8. Apply the "zero holder" calibration.  
This operation can be done with also the S-flex brake fit inside the brake holder.
9. Apply the "sensor offset" calibration  
Note the calibration depends on the feeder inclination.  
If changed, a new "sensor offset" calibration is request for an accurate tension measurement.  
"Sensor offset" calibration must be done with sensor clean and without yarn inside the sensor.
10. Move the brake in MANUAL mode into the desired position, thread the yarn through the feeder and ATC sensor, paying attention the yarn is correctly set in the sensor.

ATC-W is ready to be used. Consult to the user manual for the correct use of the device.



**Chrono X4, XD X4, XD X3 Plus, HD X3**

After disassembling, it is necessary to install the spool-body part by part to avoid damaging the parts. Secure the bellow properly with plastic straps (1).



Be sure that the carrier pin fits into the keygroove in the motor shaft (2).

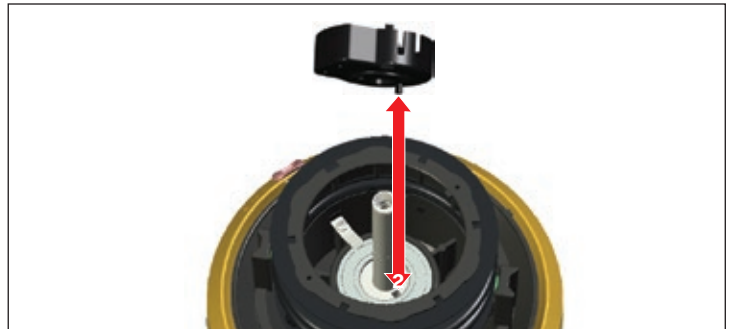

Insert the two screws (four screws in HD X3) for the rubber bellows (3) and be sure they are properly tightened with the correct key. (Torx T10)

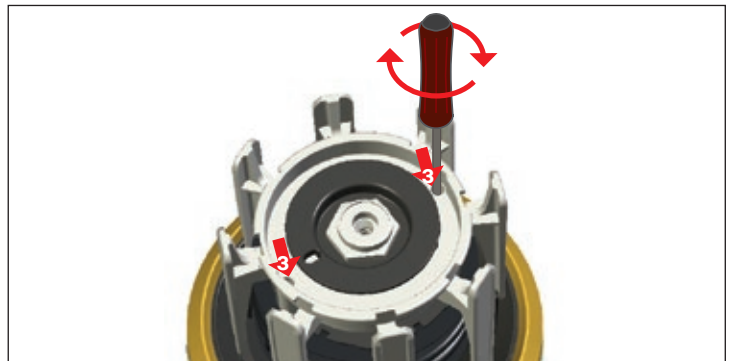

Turn the winding disc (4) when holding the centre nut (5) to get the balance weight in position. When correct, the disc can easily be moved 180° only.

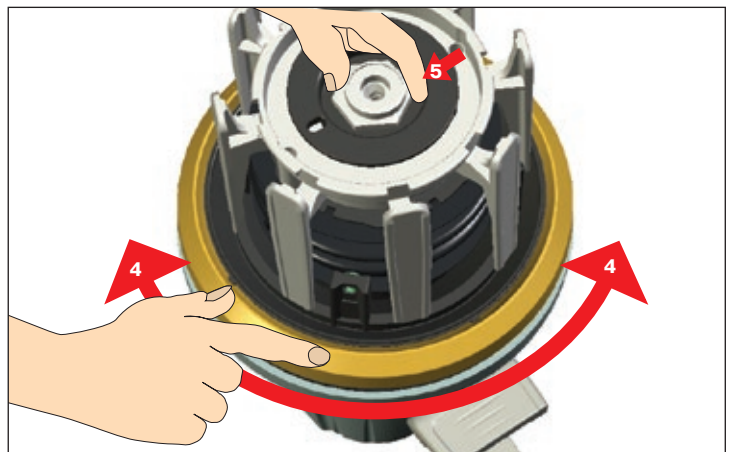

Install the centre screw, outer rubber bellows, spoolbody and cover. Set the yarn separation to a suitable position to be sure it is correctly assembled.



**LUBRICATION**

The unit requires no extra lubrication.

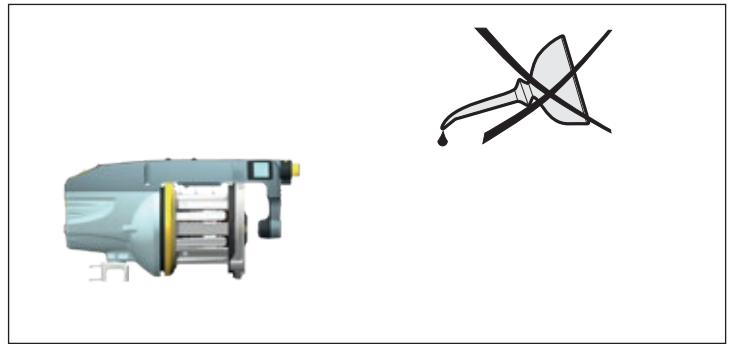

**CONNECTIONS**



**WARNING**

Always turn off the main switch or isolate the power supply and disconnect the air supply before connecting or disconnecting the feeder, the control board or any of the circuit boards.

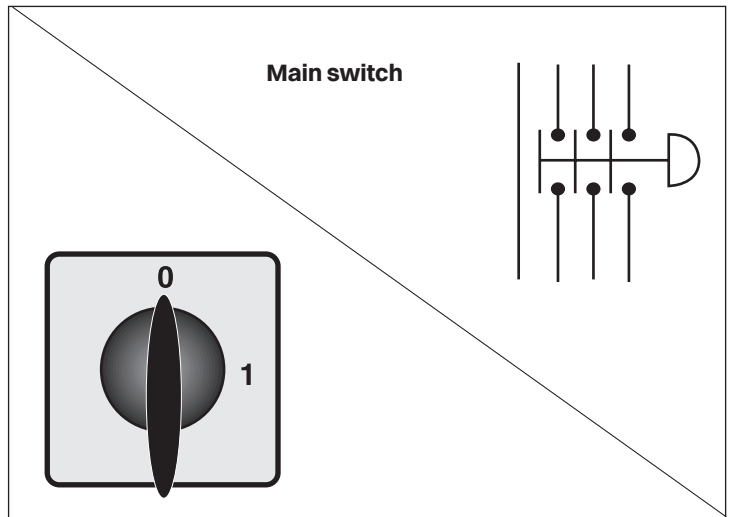

**NOTE**

The connector cover must be assembled before re-start.

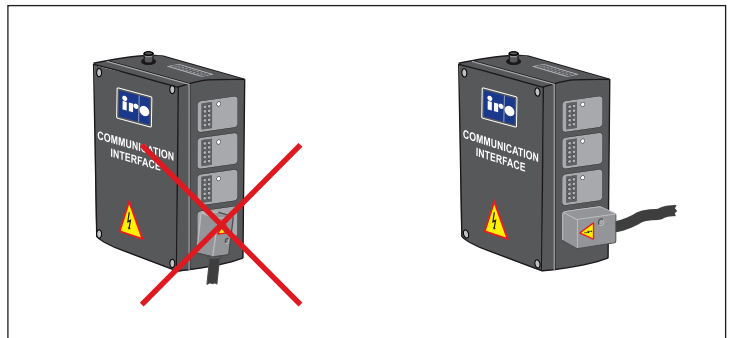

**IRO/ ROJ TOOL KIT**

It is recommended to use an IRO tool kit, with specialised tools, to ensure easy and correct disassembly/ assembly of IRO feeders during maintenance work. Please contact your local IRO service station for further information.

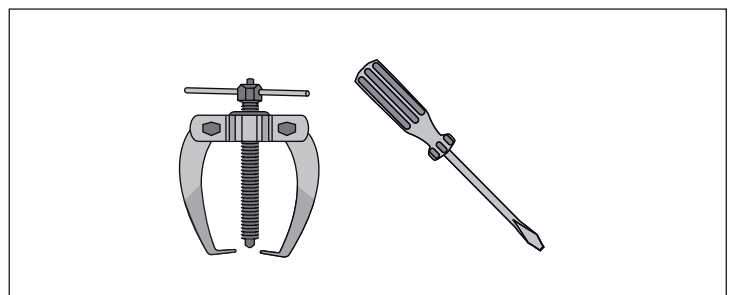

**CLEANING**

It is recommended to carry out a periodical cleaning of any lint or dust accumulation on the feeder and the control box.

**NOTE**

**Avoid the use of compressed air when cleaning the feeder.**

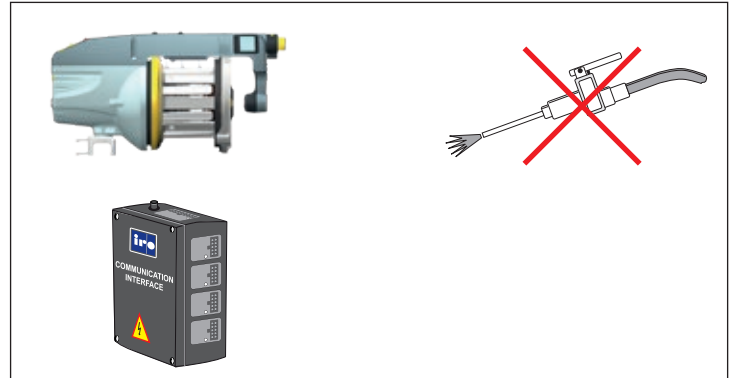

**XD X3 Plus, HD X3**

**Cleaning the spool body**

Remove the brush holder by pressing the button (1) on the top. Clean the spool body with compressed air.

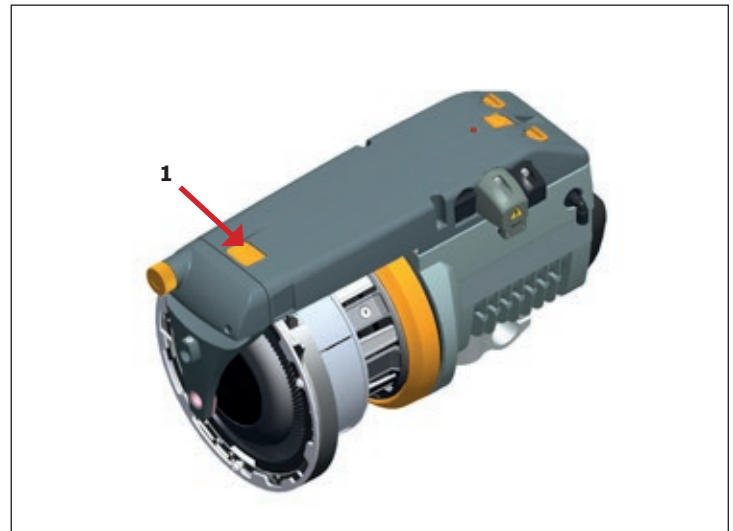

**CAUTION**

**If the brushholder is completely removed it is important to clean the piston and its seat (2) with compressed air to prevent dust to enter and disturb the normal piston movement.**

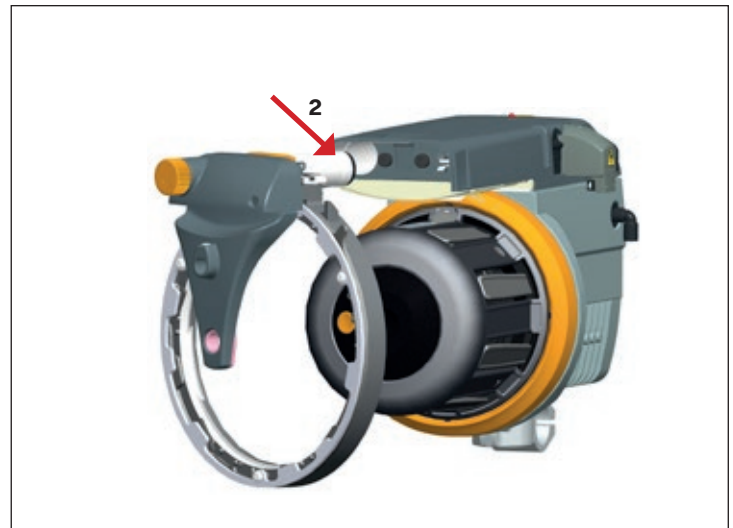

Luna X4, Chrono X4, XD X4

Fault	Check in the following order	
	Optical sensor	Mechanical sensor
Feeder will not start	1 - 2 - 3 - 4 - 6 - 7 - 8 - 24 - 25 - 26	1 - 2 - 3 - 5 - 6 - 7 - 8 - 24 - 25 - 26
Feeder will not stop	2 - 4 - 24 - 25	9 - 13 - 5 - 15 - 24 - 25
Low or empty yarn store	4 - 3 - 13 - 9 - 8 - 21 - 14 - 24 - 25 - 27 - 26	17 - 3 - 5 - 16 - 13 - 9 - 8 - 21 - 24 - 25 - 27 - 26
Input yarn breaks frequently	22 - 10 - 13	22 - 10 - 18 - 14
Output yarn breaks frequently	11 - 20 - 12 - 19 - 23	11 - 20 - 12 - 19 - 23
Fuses blow repeatedly	25 - 28	25 - 28
Feeder warning light flashes slowly	4	9 - 13
Feeder warning light flashes rapidly	3 - 9 - 8 - 27	3 - 9 - 8 - 27
Feeder warning light continuously on	29	29

No	Possible causes	Remedies	See page
1.	Incorrect S/Z switch position	Set the S/Z switch in appropriate position	22
2.	Incorrect spoolbody position	Ensure the sensor unit is positioned upwards	26
3.	Winding disc jammed	Free and clean the winding disc	54
4.	Contaminated sensor or mirror	Clean the sensor and mirror using a mild cleaning agent	26
5.	Sensor arms jammed	Free the arms and clean the sensing unit	54
6.	Faulty cable connections	Check and rectify	6-9
7.	Fuses blown	Replace the relevant fuse	8-9
8.	Mains supply / primary voltage fault	Check the mains supply and connections	6-9
9.	Insufficient input tension	Increase the input tension	-
10.	Excessive input tension	Reduce the input tension	-
11.	Insufficient balloon control	Increase the balloon control	28, 37
12.	Excessive output tension	Reduce the output tension	28, 37
13.	Excessive yarn separation	Reduce the yarn separation	22
14.	Incorrect dip switch J1 setting	Reposition dip switch	16
15.	Excessive pressure on max sensor arm	Reduce the spring pressure	26
16.	Max sensor bouncing	Increase the spring pressure	26
17.	Insufficient max speed setting	Increase the max speed setting	18
18.	Excessive max speed setting	Reduce the max speed setting	18
19.	Insufficient yarn store	See "low or empty yarn store" under "fault"	-
20.	Damaged balloon control	Repair/replace all defective parts	3
21.	Stop signal fault between control box and weaving M/C	Check all connections/cable	8-9
22.	Misalignment between the bobbin and the feeder	Realign the bobbin/feeder	-
23.	Misalignment between the feeder and the machine	Realign the feeder/machine	-
24.	Defect yarn store sensor unit	Replace the relevant sensor unit	19
25.	Defective motor circuit board	Replace the relevant circuit board	7
26.	Defective fuse panel	Replace the relevant fuse panel	8-9
27.	Defective control box interface	Replace the relevant interface	8-9
28.	Defective feeder connection cable	Replace the relevant connection cable	-
29.	Yarn break	Re-thread the feeder	23-24



**XD X3 Plus**

Fault	Check in the following order
Feeder will not start	1 - 2 - 3 - 4 - 6 - 7 - 8 - 24 - 25 - 26
Feeder will not stop	2 - 4 - 24 - 25
Low or empty yarn store	4 - 3 - 13 - 8 - 21 - 24 - 25 - 27 - 26
Input yarn breaks frequently	22 - 13
Output yarn breaks frequently	11 - 20 - 12 - 19 - 23
Fuses blow repeatedly	25 - 28
Feeder warning light flashes slowly	4
Feeder warning light flashes rapidly	3 - 8 - 27
Feeder warning light continuously on	29

No	Possible causes	Remedies	See page
1.	Incorrect S/Z switch position	Set the S/Z switch in appropriate position	22
2.	Incorrect spoolbody position	Ensure the sensor unit is positioned upwards	26
3.	Winding disc jammed	Free and clean the winding disc	54
4.	Contaminated sensor or mirror	Clean the sensor and mirror using a mild cleaning agent	26
6.	Faulty cable connections	Check and rectify	6, 10-13
7.	Fuses blown	Replace the relevant fuse	10-13
8.	Mains supply / primary voltage fault	Check the mains supply and connections	6, 10-13
11.	Insufficient balloon control	Increase the balloon control	28
12.	Excessive output tension	Reduce the output tension	28
13.	Excessive yarn separation	Reduce the yarn separation	22
19.	Insufficient yarn store	See "low or empty yarn store" under "fault"	-
20.	Damaged balloon control	Repair/replace all defective parts	3
21.	Stop signal fault between control box and weaving M/C	Check all connections/cable	10-13
22.	Misalignment between the bobbin and the feeder	Realign the bobbin/feeder	-
23.	Misalignment between the feeder and the machine	Realign the feeder/machine	-
24.	Defect yarn store sensor unit	Replace the relevant sensor unit	20
25.	Defective motor circuit board	Replace the relevant circuit board	10
26.	Defective fuse panel	Replace the relevant fuse panel	10-13
27.	Defective control box interface	Replace the relevant interface	10-13
28.	Defective feeder connection cable	Replace the relevant connection cable	-
29.	Yarn break	Re-thread the feeder	24

**HD X3**

Fault	Check in the following order	
	Optical sensor	Mechanical sensor
Feeder will not start	1 - 2 - 3 - 4 - 6 - 7 - 8 - 24 - 25 - 26	1 - 2 - 3 - 5 - 6 - 7 - 8 - 24 - 25 - 26
Feeder will not stop	2 - 4 - 24 - 25	9 - 13 - 5 - 15 - 24 - 25
Low or empty yarn store	4 - 3 - 13 - 9 - 8 - 21 - 24 - 25 - 27 - 26	17 - 3 - 5 - 16 - 13 - 9 - 8 - 21 - 24 - 25 - 27 - 26
Input yarn breaks frequently	22 - 10 - 13	22 - 10 - 18 - 14
Output yarn breaks frequently	11 - 20 - 12 - 19 - 23	11 - 20 - 12 - 19 - 23
Fuses blow repeatedly	25 - 28	25 - 28
Feeder warning light flashes slowly	4	9 - 13
Feeder warning light flashes rapidly	3 - 9 - 8 - 27	3 - 9 - 8 - 27
Feeder warning light continuously on	29	29

No	Possible causes	Remedies	See page
1.	Incorrect S/Z switch position	Set the S/Z switch in appropriate position	22
2.	Incorrect spoolbody position	Ensure the sensor unit is positioned upwards	27
3.	Winding disc jammed	Free and clean the winding disc	54
5.	Sensor arms jammed	Free the arms and clean the sensing unit	54
6.	Faulty cable connections	Check and rectify	6, 10-13
7.	Fuses blown	Replace the relevant fuse	11-13
8.	Mains supply / primary voltage fault	Check the mains supply and connections	6, 10-13
9.	Insufficient input tension	Increase the input tension	-
10.	Excessive input tension	Reduce the input tension	-
11.	Insufficient balloon control	Increase the balloon control	28
12.	Excessive output tension	Reduce the output tension	28
17.	Insufficient max speed setting	Increase the max speed setting	18
18.	Excessive max speed setting	Reduce the max speed setting	18
19.	Insufficient yarn store	See "low or empty yarn store" under "fault"	-
20.	Damaged balloon control	Repair/replace all defective parts	3
22.	Misalignment between the bobbin and the feeder	Realign the bobbin/feeder	-
23.	Misalignment between the feeder and the machine	Realign the feeder/machine	-
24.	Defect yarn store sensor unit	Replace the relevant sensor unit	21
25.	Defective motor circuit board	Replace the relevant circuit board	10
26.	Defective fuse panel	Replace the relevant fuse panel	10-13
27.	Defective control box interface	Replace the relevant interface	10-13
28.	Defective feeder connection cable	Replace the relevant connection cable	-
29.	Yarn break	Re-thread the feeder	25
30.	Sensor out of calibration	Execute automatic sensor calibration	27

**▶ VANDEWIELE**  
**SWEDEN AB**

**VANDEWIELE SWEDEN AB**

Box 54  
 SE-523 22 Ulricehamn  
 Sweden

**EC DECLARATION OF CONFORMITY**

Guarantee that machine type:

**Luna X4, Chrono X4, XD X4, XD X3 Plus and HD X3**

is manufactured in conformity with the provisions of the following  
 EC directives and applicable amendments:

Safety of machinery	2006/42/EC	EN ISO 111 11-1
Low voltage equipment	2014/35/EC	EN ISO 111 11-1
Electromagnetic compatibility	2014/30/EC	EN ISO 111 11-1

*Pär Josefsson, Manager Product and Development department, 2023-05-10*